

Design

①

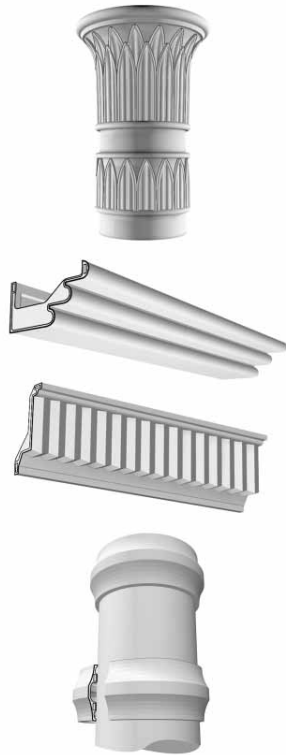

Formglas

Founded in 1962, Formglas is the world's leading manufacturer of glassfiber reinforced cast products for interior use. Production plants in Toronto - Canada and Kuala Lumpur - Malaysia, employ over 200 people. An engineering office in Tokyo - Japan and a world wide agent network ensures expert advise anywhere.

The majority of our products are made for specific projects using custom molds and tooling. However, this catalogue shows existing molds from which parts can be made to help reduce costs and shorten delivery times.

CATALOGUE POINTERS:

- No products are stocked.
- Items are always factory quoted since quantities, material type, etc., all influence the price.
- Please check availability since molds deteriorate and may no longer exist.
- Radius / curved mouldings require custom molds / tooling.
- G.R.G. (Gypsum) mouldings - 8'-0" (2440mm) long. QuarryCast® & MetalCast® mouldings - 4'- 0" (1220mm) long.
- Dimensional detail drawings are available for all catalogue items.
- Shop drawings are submitted for approval prior to manufacturing all orders.

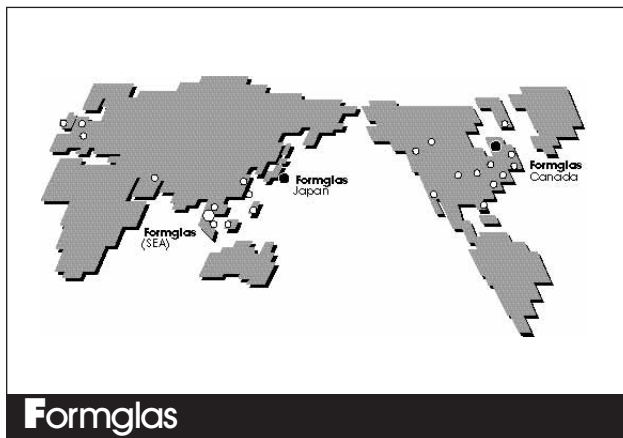

Formglas Inc.

20 Toro Road, North York, ON CANADA M3J 2A7
 Tel: (416) 635-8030 Fax: (416) 635-6588
 Web Site: <http://www.formglas.com>

Formglas (SEA) Sdn Bhd

Lot 590, Persiaran Raja Lumu Pandamaran Ind. Area,
 42000 Port Klang Selangor Darul Ehsan, Malaysia
 Tel: (603) 368-1299 Fax: (603) 367-7795

Formglas Japan Inc.

1-10 - 4 Shinjuku Shinjuku-Ku, Tokyo 160, JAPAN
 Tel: (03) 3225-8397 Fax: (03) 3225-9153

MATERIAL TYPES:

GENERAL:

- All types have zero or near zero flame / smoke ratings.
 - Thickness, depending on type - 1/8" - 5/16" (3 - 8mm) with thicker edges.
 - Weight, depending on type - 1 1/2 - 3 lbs/sq.ft. (7 1/2 - 15kg./sq.m.).
1. G.R.G. (Glassfiber Reinforced Gypsum) is a "thin cast" gypsum that requires field finishing.
 - Joints can be taped and painting is similar to drywall finishing (never high gloss).
 - For interior use only.
 - Installed by the "drywall" trade (Section 9000).
 2. QuarryCast® (Glassfiber Reinforced Minerals) is a molded stone that is pre - finished.
 - Appearance of lime / sand stone
 - For interior use only.
 - Installed by carpenters (Section 6200).
 3. MetalCast® (Glassfiber Reinforced Minerals & Metal Powders) has the appearance of cast metal.
 - Burnished look (polished look not available).
 - For interior use only.
 - Installed by carpenters (Section 6200).
 4. G.R.C. (Glassfiber Reinforced Cement) is grey in colour and always requires field finishing.
 - Joints are caulked and most cement finishes are acceptable (never high gloss).
 - Suitable as decorative elements, not for building cladding.
 - For exterior use.
 - Installed by the "drywall" trade or carpenters.

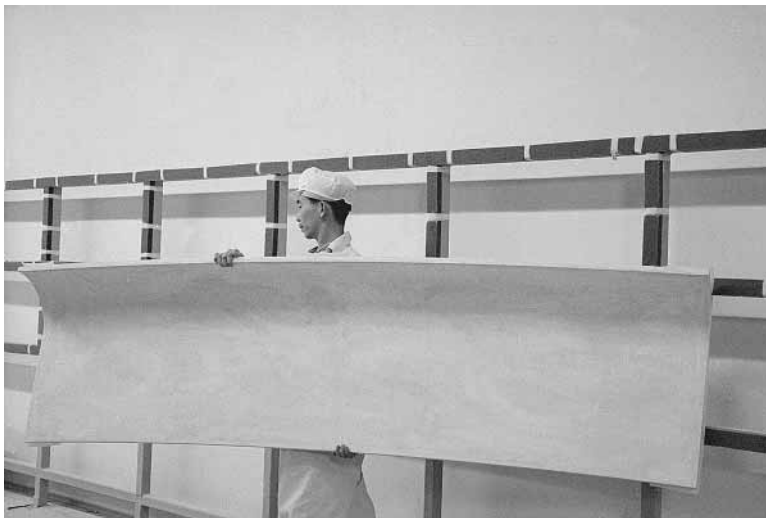

ALL FORMGLAS PRODUCTS ARE LIGHTWEIGHT,
EASY TO WORK WITH AND NON-FLAMMABLE.

COLUMNS

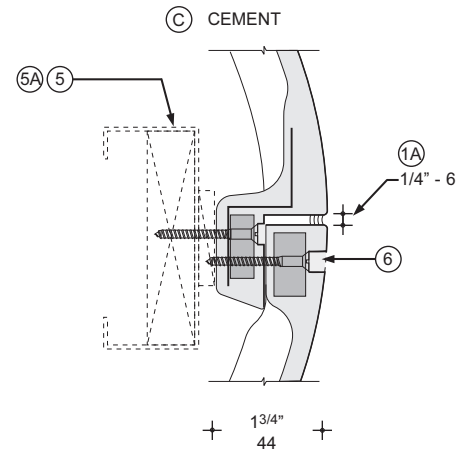
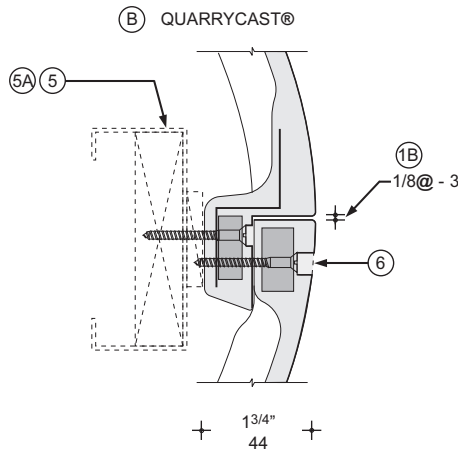
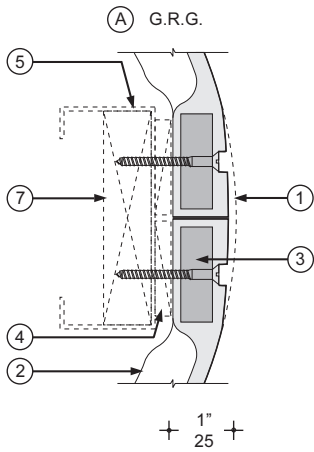
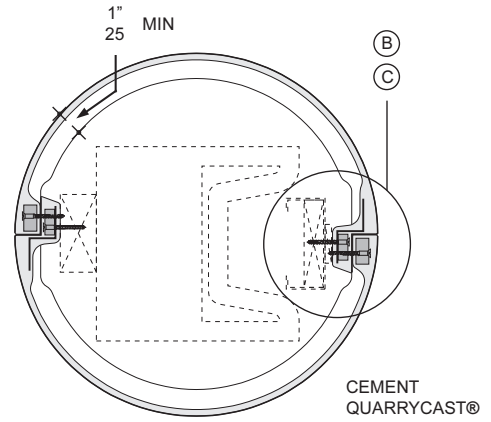
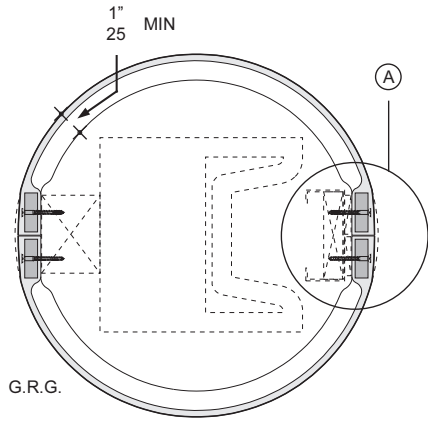

- ① TAPE - G.R.G.
- ①A CAULK - CEMENT
- ①B GROUT OR CAULK - QUARRYCAST®
- ② END FLANGES OR INTERMEDIATE REINFORCING
- ③ BUILT-IN PLYWOOD REINFORCING
- ④ SHIMS [INSTALLER]
- ⑤ SUPPORTS [INSTALLER]
- ⑤A SUPPORTS NOT REQ. FOR 8' [2440] HIGH OR LESS
- ⑥ COUNTERSUNK FASTENERS [FILLED]
- ⑦ PLYWOOD BLOCKING [IF REQ.]

SERIES #10000
STANDARD COLUMN DIAMETERS ϕ

6" (152)	8" (203)	9" (229)	10" (254)
12" (305)	14" (356)	15" (381)	16" (406)
18" (457)	20" (508)	21" (533)	22" (559)
24" (610)	26" (660)	27" (685)	28" (711)
30" (762)	34" (864)	36" (914)	42" (1067)
48" (1219)			

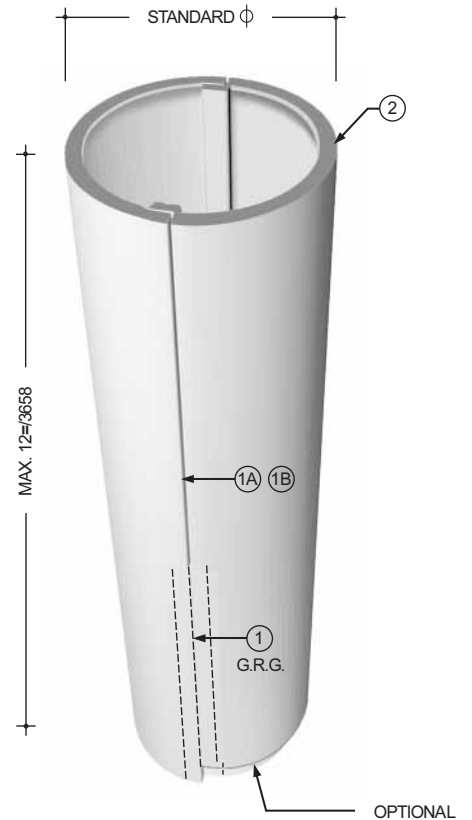

20 TORO ROAD
NORTH YORK, ONT, M3J 2A7
KUALA LUMPUR, MALAYSIA
TOKYO, JAPAN

TEL (416) 635-8030
FAX (416) 635-6588
TEL (603) 368-1299
TEL (03) 3225-8397

COLUMNS

OVAL DISPLAY COLUMN

Technical drawings of various oval display columns, including dimensions and part numbers.

Column #10514: Height: 7' - 5/8" (2428) (FIXED HEIGHT). Top width: 18" 457. Middle diameter: 11" 279 ϕ . Base diameter: 14" 356 ϕ . Base width: 17" 432.

Column #11212: Height: 12' - 0" 3657 MAX. Top width: MAX. (A). Middle diameter: MAX. (B). Note: CAPS CAN BE SHORTER.

Column #11218: Height: 12' - 0" 3657 MAX. Top width: MAX. (A). Middle diameter: MAX. (B). Note: CAPS CAN BE SHORTER.

Column #11137 (Curved): Height: 11' - 0" 3353 MAX. Top width: 38" 965. Middle diameter: 13" 330 ϕ .

Column #10910: Height: 8' - 0" (2438) (FIXED HEIGHT). Top width: 12" 304. Middle diameter: 10" 254 ϕ . Base width: 12" 304.

Column #11010: Height: 5' - 11" (1803), 8' - 0" (2438), 9' - 0" (2743). Top width: 14 1/2" 368. Middle diameter: 9" 229 ϕ . Base diameter: 10" 254 ϕ . Base width: 14 1/2" 368.

TYPE	ϕ	MAX. A	MAX. B
#11212	12" 304	20" 508	24" 609
#11218	18" 457	28" 711	28" 711



20 TORO ROAD
NORTH YORK, ONT, M3J 2A7
KUALA LUMPUR, MALAYSIA
TOKYO, JAPAN

TEL (416) 635-8030
FAX (416) 635-6588
TEL (603) 368-1299
TEL (03) 3225-8397

COLUMNS



+
AS REQ.
MAX. 48"
1219
+



+
AS REQ.
MAX. 48"
1219
+

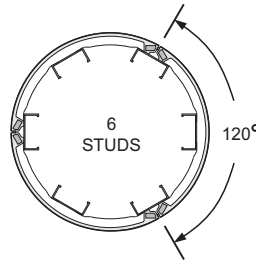

2 X 180°

Φ	TYPE	
20"/508	PLAIN	#18420
	FLUTED	#18520
24"/609	PLAIN	#18424
	FLUTED	#18524

3 X 120°

Φ	TYPE	
30"/762	PLAIN	#18430
	FLUTED	#18530
36"/914	PLAIN	#18436
	FLUTED	#18536
41"/1041	PLAIN	#18441
	FLUTED	#18541

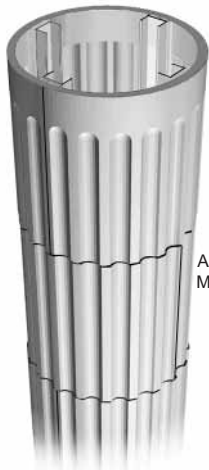
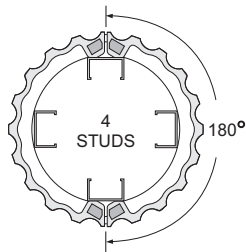

+
AS REQ.
MAX. 42"
1067
+

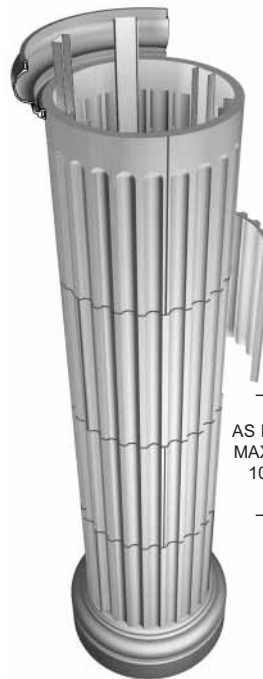

+
AS REQ.
MAX. 42"
1067
+

SEE PAGE 9
FOR CAPITALS & BASES



20 TORO ROAD
NORTH YORK, ONT, M3J 2A7
KUALA LUMPUR, MALAYSIA
TOKYO, JAPAN

TEL (416) 635-8030
FAX (416) 635-6588
TEL (603) 368-1299
TEL (03) 3225-8397

COLUMNS

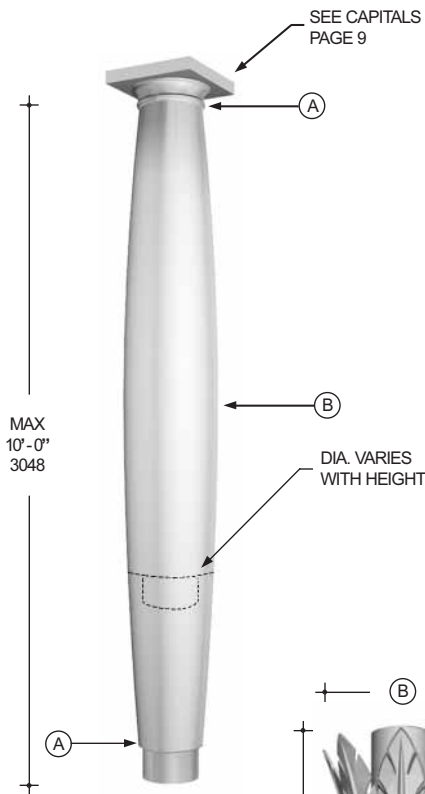

TYPE	A	B
#18614	9" 229	14" 356
#18618	12" 304	18" 457
#18622	16" 406	22" 559

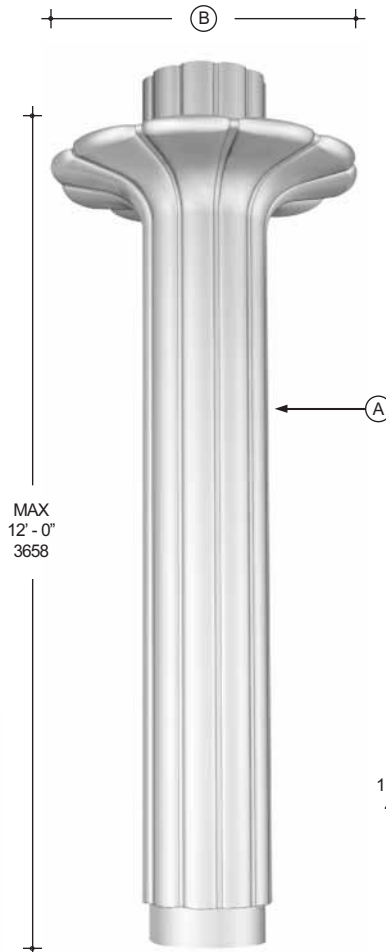

TYPE	A	B
#18710	10" 254	26" 660
#18713	13" 330	32" 813
#18717	17 ¹ / ₄ " 438	42 ¹ / ₂ " 1080

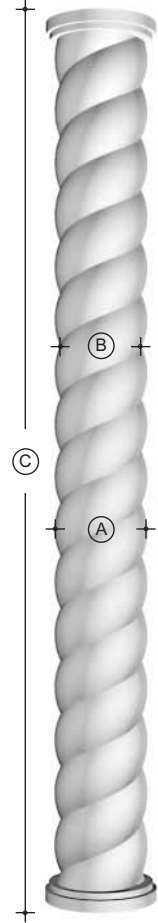

TYPE	A	B	C
#18808	8" 203	6" 152	7'-0" 2134
#18812	12" 304	10" 254	10'-6" 3200
#18816	16" 406	13 ¹ / ₂ " 343	12'-0" 3658

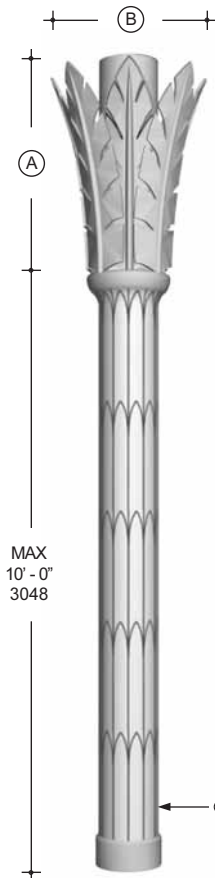

TYPE	Φ	A	B
#18909	9" 229	27" 686	23" 584
#18912	12" 304	34" 864	29" 737

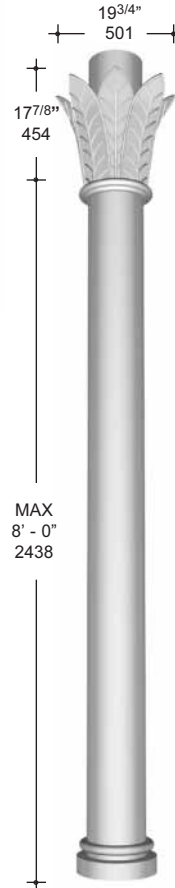

SHAFT
8"
203
#18908



20 TORO ROAD
NORTH YORK, ONT, M3J 2A7
KUALA LUMPUR, MALAYSIA
TOKYO, JAPAN

TEL (416) 635-8030
FAX (416) 635-6588
TEL (603) 368-1299
TEL (03) 3225-8397

COLUMN SHAFTS

CAPITALS & BASES ARE SEPARATE AND INTERCHANGEABLE

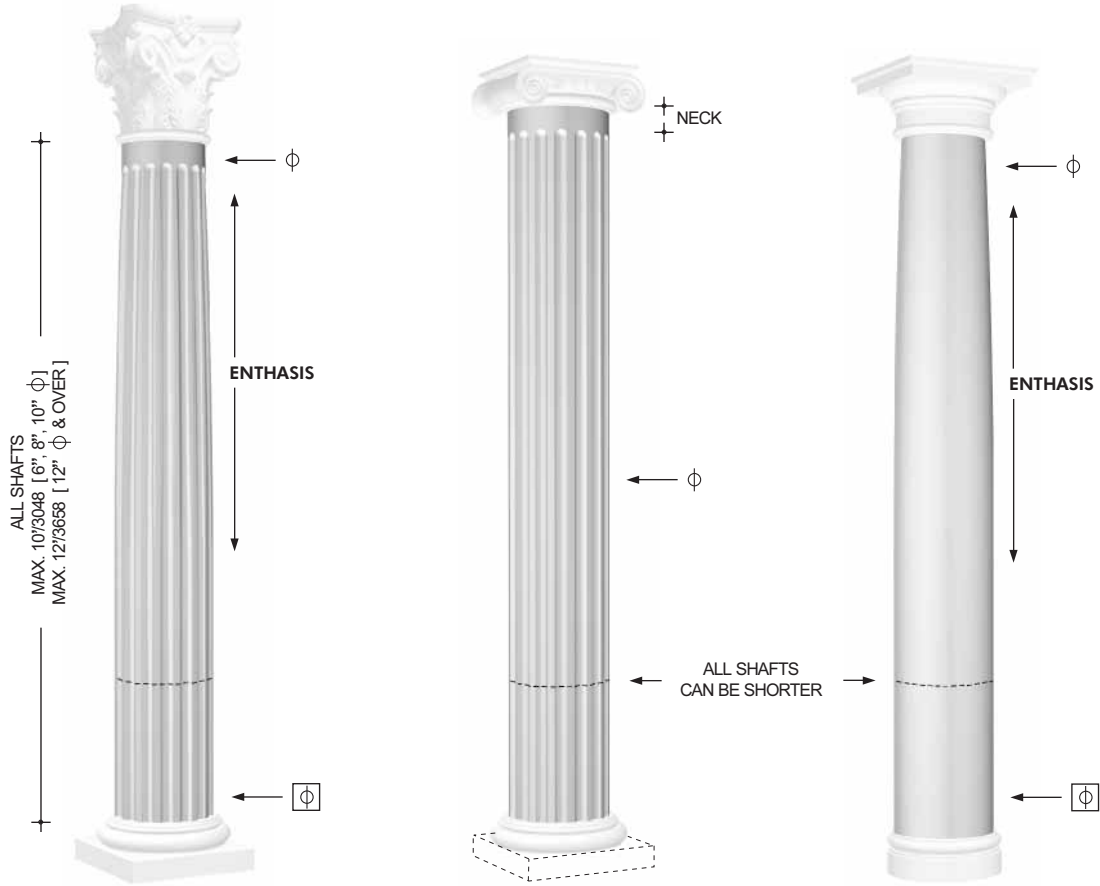

TAPER FLUTED

TYPE	TOP φ	AT BASE φ
#18006	6"/152	7 ¹ / ₈ "/181
#18008	8"/203	9 ¹ / ₄ "/235
#18010	10"/254	11 ¹ / ₂ "/292
#18012	12"/304	13 ³ / ₄ "/349
#18014	14"/356	16"/406
#18016	16"/406	18 ¹ / ₄ "/464
#18018	18"/457	20 ¹ / ₂ "/521
#18020	20"/508	22 ¹ / ₂ "/572
#18024	24"/609	27 ¹ / ₄ "/692

FLUTED

TYPE	φ
#18106	6"/152
#18108	8"/203
#18110	10"/254
#18112	12"/304
#18114	14"/356
#18116	16"/406
#18118	18"/457
#18120	20"/508
#18124	24"/609
#18130	30"/762
#18136	36"/914
#18141	41"/1041

TAPER PLAIN

TYPE	TOP φ	AT BASE φ
#18206	6"/152	7"/178
#18208	8"/203	9 ¹ / ₄ "/235
#18210	10"/254	11 ¹ / ₂ "/292
#18212	12"/304	13 ³ / ₄ "/349
#18214	14"/356	16"/406
#18216	16"/406	18 ¹ / ₄ "/464
#18218	18"/457	20 ¹ / ₂ "/521
#18220	20"/508	22 ³ / ₄ "/578
#18224	24"/609	27 ¹ / ₄ "/692
#18228	28"/711	32"/812

1. MOST SHAFTS ARE SHIPPED IN HALVES, BUT QUARRYCAST® & METALCAST® SHAFTS OVER 20" φ & 8' - 0" HIGH HAVE TO BE MADE IN SMALL SECTIONS.
2. SHAFTS ARE NON-STRUCTURAL.

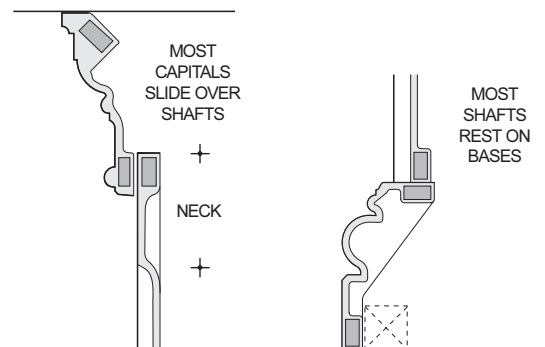

20 TORO ROAD
NORTH YORK, ONT, M3J 2A7
KUALA LUMPUR, MALAYSIA
TOKYO, JAPAN

TEL (416) 635-8030
FAX (416) 635-6588
TEL (603) 368-1299
TEL (03) 3225-8397

COLUMN CAPITALS & BASES
SHAFTS ARE SEPARATE AND INTERCHANGEABLE

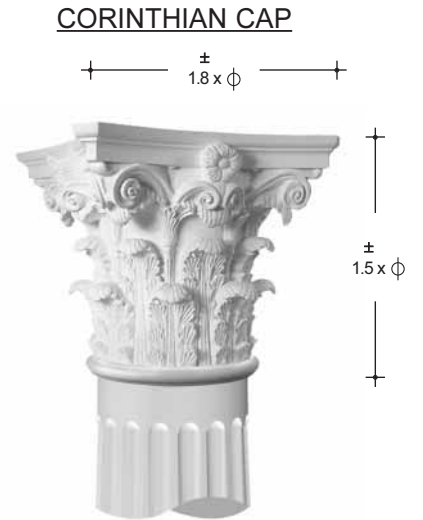
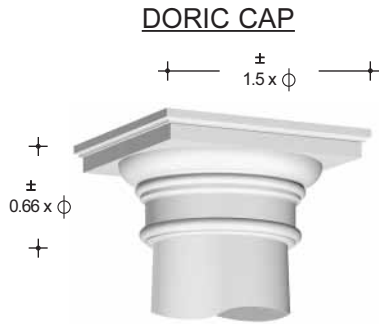

CAPITALS

TAPERED OR STR'T SHAFT AT TOP ϕ	DORIC CAP	IONIC CAP	CORINTH. CAP	DORIC RING CAP
6"/152	#27106	#27406	#27006	#27306
8"/203	#27108	#27408	#27008	#27308
9"/229	#27109			
10"/254	#27110	#27410	#27010	#27310
12"/304	#27112	#27412	#27012	#27312
14"/356	#27114		#27014	#27314
16"/406	#27116	#27416	#27016	#27316
18"/457	#27118		#27018	#27318
20"/508	#27120	#27420	#27020	#27320
24"/609	#27124	#27424	#27024	#27324
28"/711	#27128	#27428	#27028	#27328
30"/762				#27330
32"/813				#27332
36"/914				#27336
41"/1041				#27341

BASES

STR'T SHAFT ϕ	DORIC BASE	BASE BOARD	TAPERED SHAFT AT BASE ϕ
6"/152	#27206	#27506	
	#27207		7"/178
8"/203	#27208	#27508	
9"/229	#27209		9 1/4"/235
10"/254	#27210	#27510	
12"/304	#27212	#27512	11 1/2"/292
14"/356	#27214	#27514	13 3/4"/349
16"/406	#27216	#27516	16"/406
18"/457	#27218	#27518	18 1/4"/464
20"/508	#27220	#27520	20 1/2"/521
24"/609	#27224	#27524	22 3/4"/578
28"/711	#27228		27 1/4"/692
30"/762	#27230	#27530	
32"/813	#27232		32"/813
36"/914	#27236	#27536	
41"/1041	#27241		



1. STRAIGHT, TAPERED, OR FLUTED SHAFTS WILL FIT ALL CAPITALS OR BASES.
2. NORMALLY SHAFTS SLIDE THROUGH THE CAPITALS BUT SIT ON TOP OF BASES.
3. CAPITALS AND BASES ARE SHIPPED IN HALVES.

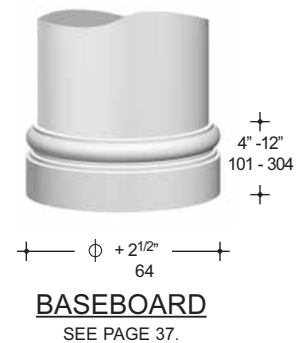
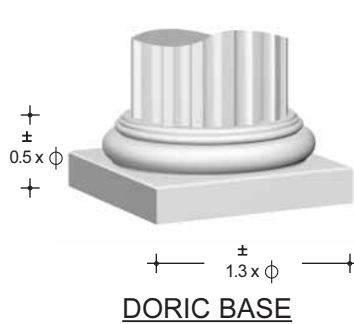
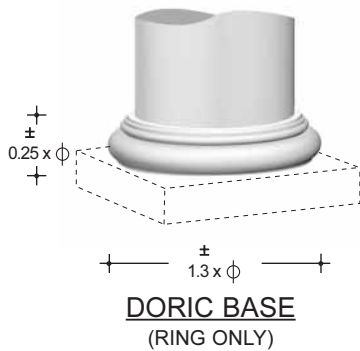

20 TORO ROAD
NORTH YORK, ONT, M3J 2A7
KUJALA LUMPUR, MALAYSIA
TOKYO, JAPAN

TEL (416) 635-8030
FAX (416) 635-6588
TEL (603) 368-1299
TEL (03) 3225-8397

CAPITALS

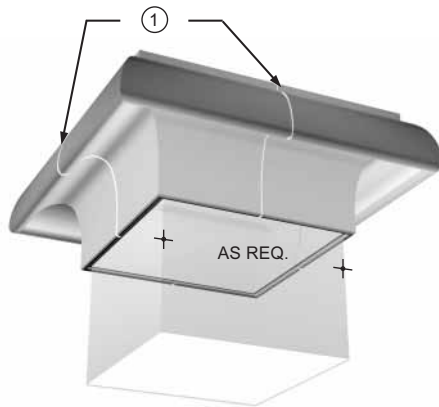
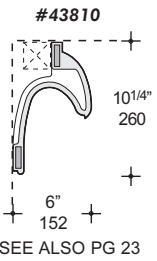
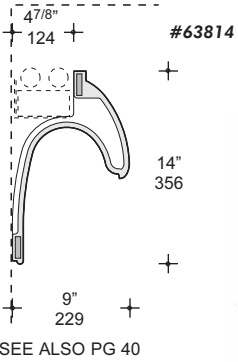
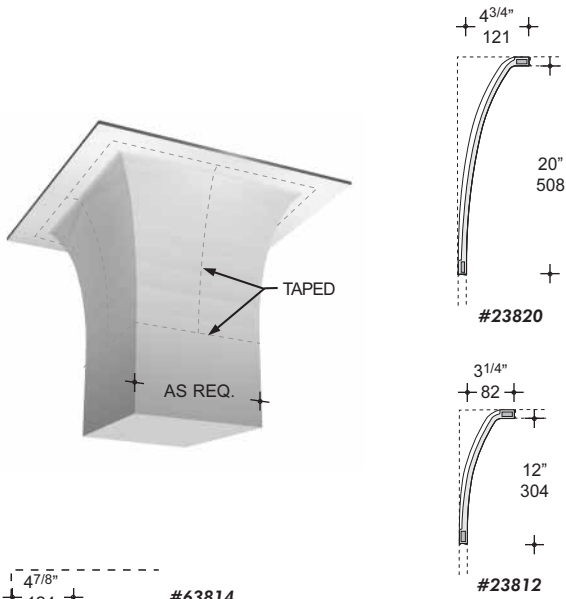

① = TAPE JOINT - G.R.G.
GROUT JOINT - QUARRYCAST®

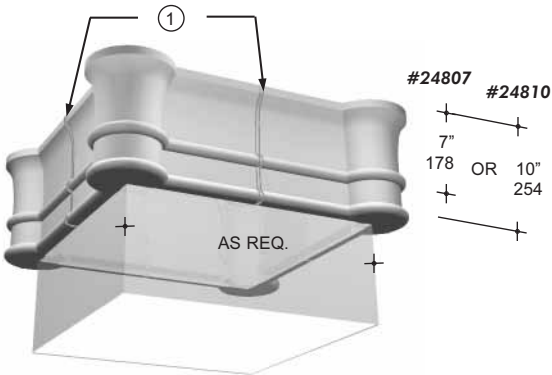

MATCHING MOLDINGS #44807 & #44810 PG. 22

DOUBLE CAPITAL

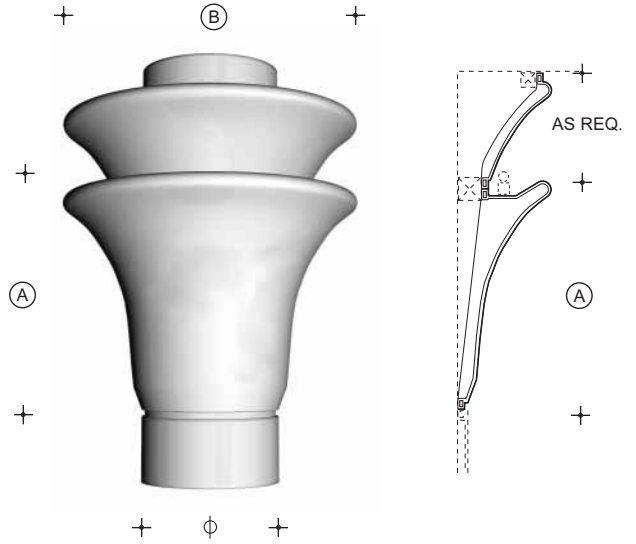

SINGLE CAPITAL

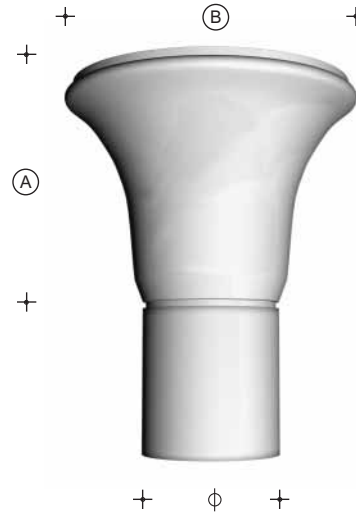

TYPE	φ	A	B
#23612	12\"/>		

TYPE	φ	A	B	D
#23710	10\"/>			

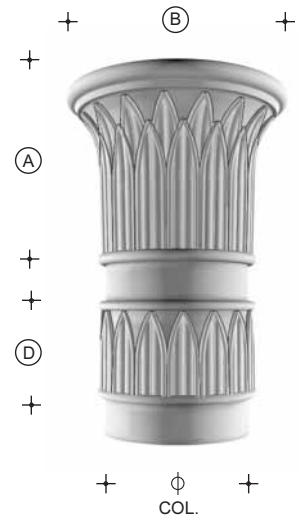

20 TORO ROAD
NORTH YORK, ONT, M3J 2A7
KUALA LUMPUR, MALAYSIA
TOKYO, JAPAN

TEL (416) 635-8030
FAX (416) 635-6588
TEL (603) 368-1299
TEL (03) 3225-8397

CAPITALS

TYPE	Φ	H
#23510	10"	5"
	254	127
#23512	12"	6"
	304	152
#23518	18"	8"
	457	203

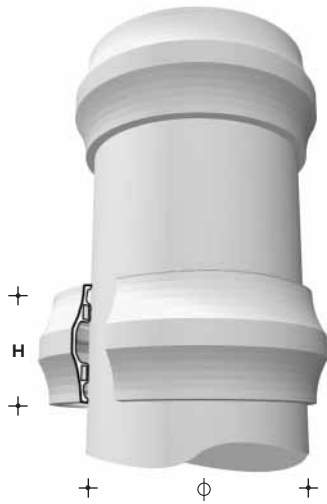

CAP

RING

BULLNOSE RINGS

TYPE	Φ	H
#23412	12"	2"
	304	51
#23414	14"	2 1/4"
	356	57
#23416	16"	2 1/2"
	406	64
#23418	18"	2 3/4"
	457	70
#23420	20"	3"
	508	76
#23424	24"	3 1/2"
	609	89

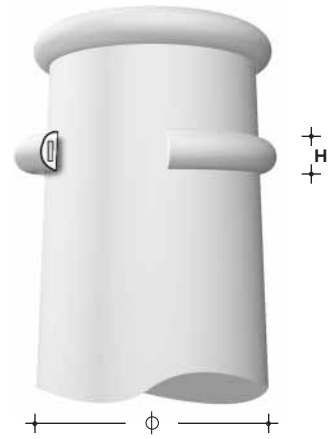

MIN .66 X DIA

AS BASES

MIN .66 X DIA

STANDARD COLUMN

AS REQ.

STANDARD COLUMN

CAP & BASE HEIGHTS ARE VARIABLE UP TO 3' - 6"(1067)

SQUARE BASES	COL. DIA.	BASE DIA.	ROUND BASES
#27806	6"	7 1/4"	#27706
	152	184	
#27809	9"	10 3/8"	#27709
	228	263	
#27812	12"	13 5/8"	#27712
	304	304	
#27816	16"	18 1/4"	#27716
	406	463	

MAX. 3'-6" 1067

MAX. 3'-6" 1067



20 TORO ROAD
NORTH YORK, ONT, M3J 2A7
KUALA LUMPUR, MALAYSIA
TOKYO, JAPAN

TEL (416) 635-8030
FAX (416) 635-6588
TEL (603) 368-1299
TEL (03) 3225-8397

CAPITALS

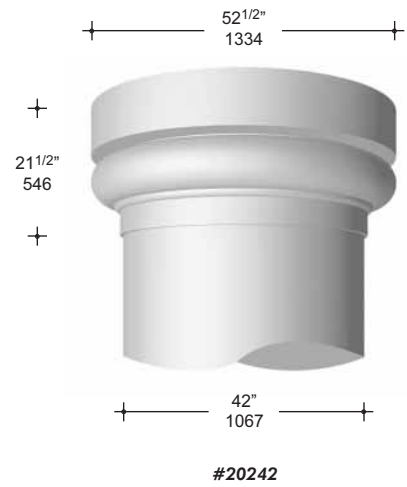
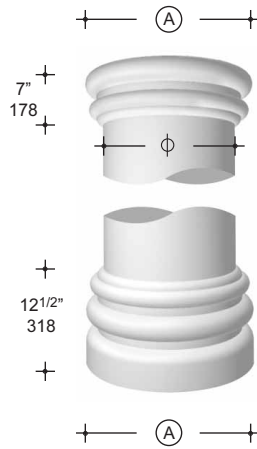
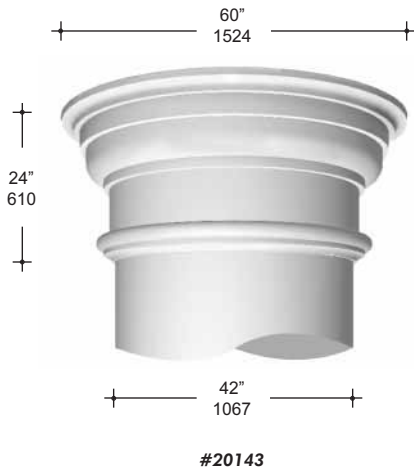

TYPE	φ	A
#21515	15" 381	20 1/4" 514
#21518	18" 457	22 3/4" 579
#21521	21" 533	26" 660
#21524	24" 610	29" 737
#21533	33" 838	37 3/4" 959

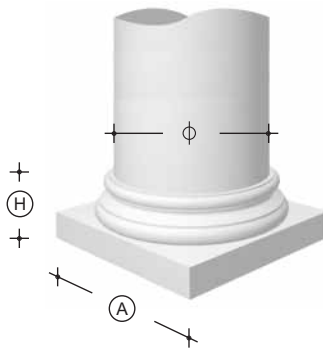
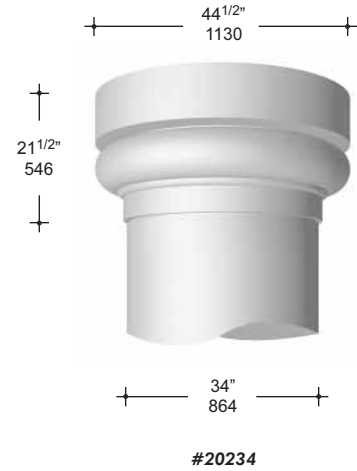
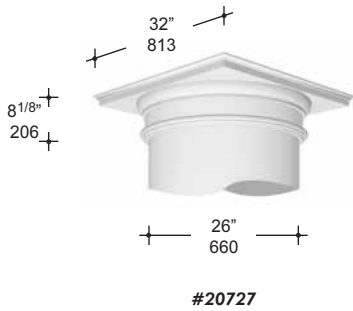

MODIFIED CORINTHIAN BASE

TYPE	φ	A	H
#21812	12" 304	16" 406	7 3/4" 197
#20514	14" 356	17 3/4" 451	9 3/8" 238
#21616	16" 406	20" 508	7 5/8" 194
#20718	18" 457	22" 559	7 3/4" 197
#20421	22" 559	28 1/2" 724	15 1/2" 394
#20724	24" 610	32" 813	12" 304
#20726	26" 660	30" 762	10" 254
#20429	30" 762	38 1/2" 978	15 3/8" 391
#20142	42" 1067	54" 1372	24" 610

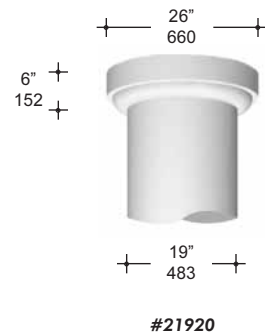
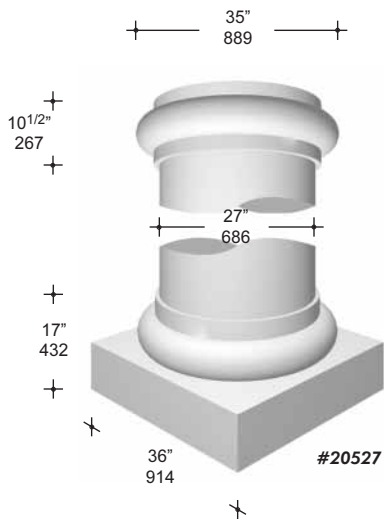

NOTE!
CAPITALS CAN BE BASES
OR
BASES CAN BE CAPITALS



20 TORO ROAD
NORTH YORK, ONT, M3J 2A7
KUALA LUMPUR, MALAYSIA
TOKYO, JAPAN

TEL (416) 635-8030
FAX (416) 635-6588
TEL (603) 368-1299
TEL (03) 3225-8397

CAPITALS

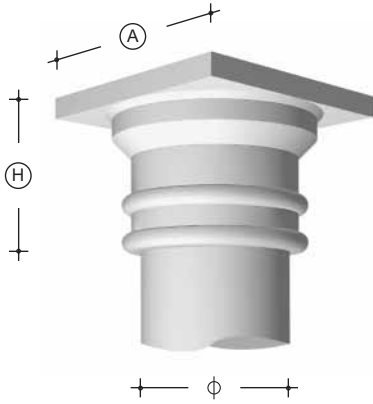

TYPE	φ	A	H
#20812	12" 304	18" 457	12 1/2" 318
#20820	20" 508	28 1/2" 724	20 1/2" 521
#20826	26" 660	34 1/2" 876	20 1/2" 521

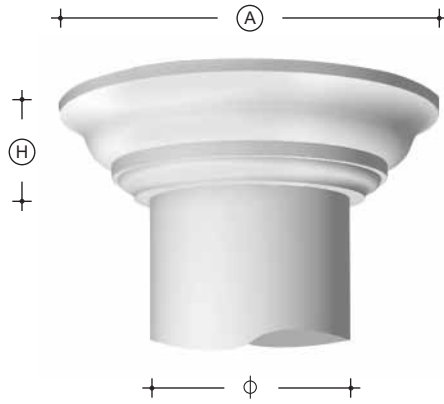

TYPE	φ	A	H
#22016	16" 406	30" 762	7 1/4" 184
#22020	20" 508	34" 864	7 1/4" 184

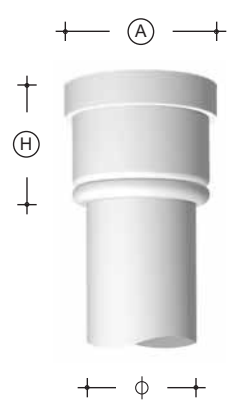

TYPE	φ	A	H
#21309	9" 229	9 3/4" 248	12 1/2" 318
#21320	20" 508	25" 635	14" 356
#21324	24" 610	29" 737	14" 356

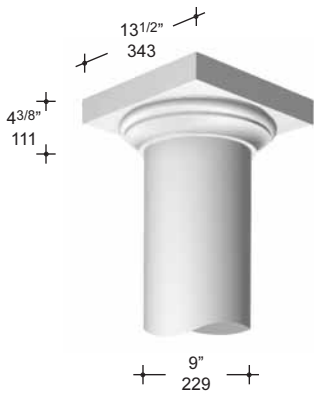

#23009

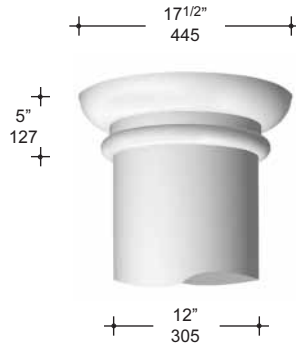

#22112

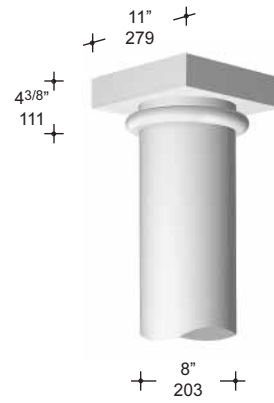

#22208

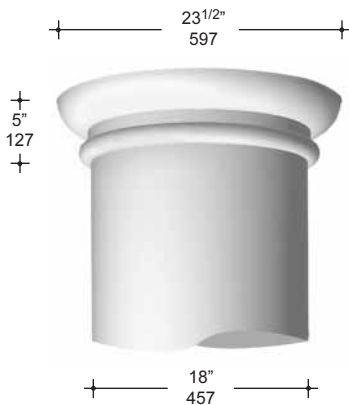

#22118

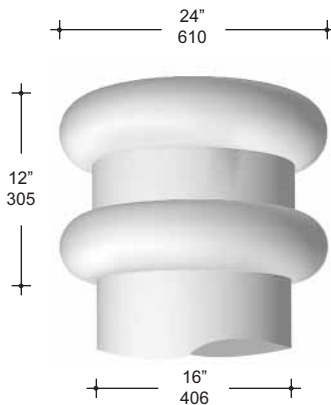

#22316

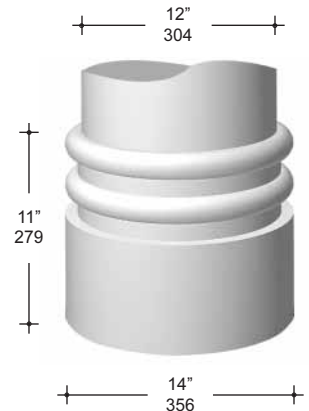

#22312



20 TORO ROAD
NORTH YORK, ONT, M3J 2A7
KUALA LUMPUR, MALAYSIA
TOKYO, JAPAN

TEL (416) 635-8030
FAX (416) 635-6588
TEL (603) 368-1299
TEL (03) 3225-8397

NOTE!
CAPITALS CAN BE BASES
OR
BASES CAN BE CAPITALS

CAPITALS & RINGS

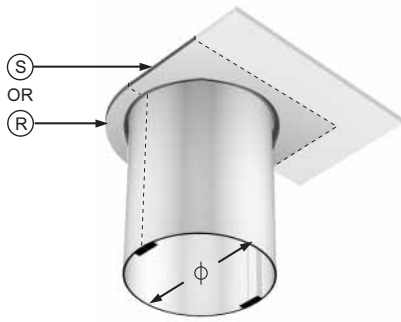

DRYWALL FLUSH

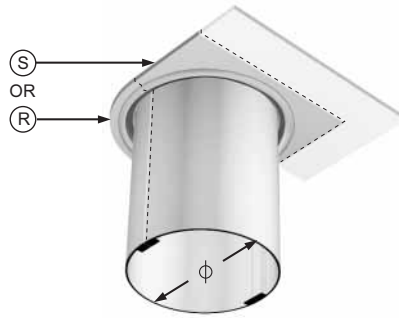

DRYWALL BULLNOSE



ACOUSTIC TILE

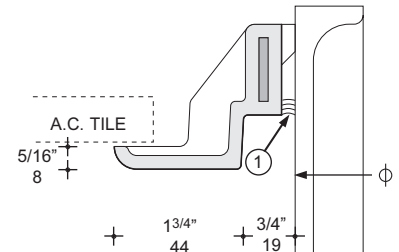
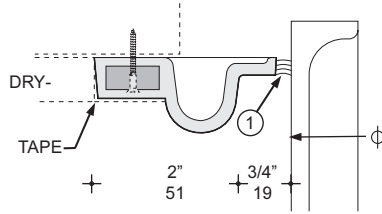
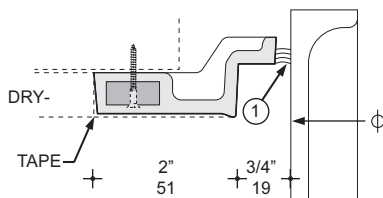

φ	12" 304	14" 356	16" 406	18" 457	20" 508	24" 609
DRYWALL FLUSH	#23012	#23014	#23016	#23018	#23020	#23024
DRYWALL BULLNOSE	#23112	#23114	#23116	#23118	#23120	#23124
ACOUSTIC TILE	#23212	#23214	#23216	#23218	#23220	#23224

SPECIFY - (S) QUARE OR (R) OUND AND 1/2" OR 5/8" DRYWALL

① = CAULKING

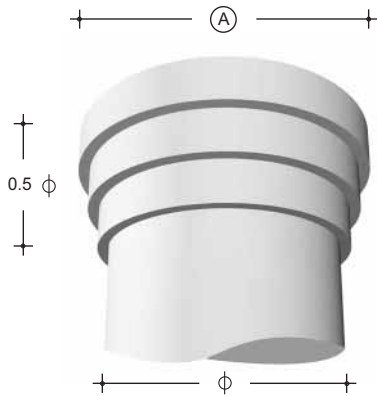

TYPE	COL. φ	STEP	
		3 STEP (A)	2 STEP (B)
#23312	12" 304	16 1/2" 419	15" 381
#23316	16" 406	20 1/2" 521	19" 483
#23320	20" 508	25 1/4" 641	23 1/2" 597
#23324	24" 609	30" 762	28" 711

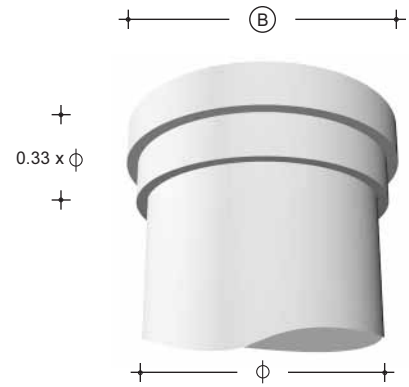

WITH SILICON GRAPHIC WORK STATIONS, FORMGLAS PERSONNEL CAN "SURFACE MODEL" IMAGES FOR PATTERN / MOLD MAKING. REAL TIME RENDERING ALLOWS UNPARALLED DESIGN FREEDOM.

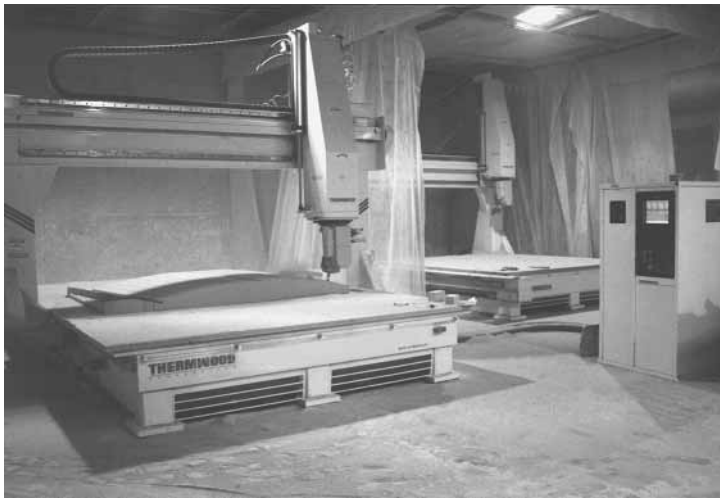

THE LATEST 5 AXIS - C.N.C. MILLING MACHINES CREATE PATTERNS / MOLDS WITH SPEEDS AND TOLERANCES NOT FEASIBLE WHEN MADE BY HAND.



DECORATIVE PATTERNS LIKE THIS CAPITAL CANNOT BE C.N.C. MACHINE CUT. FORMGLAS EMPLOYS A FULL TIME SCULPTOR TO TRANSLATE DRAWINGS INTO MODELS.



20 TORO ROAD
NORTH YORK, ONT, M3J 2A7
KUALA LUMPUR, MALAYSIA
TOKYO, JAPAN

TEL (416) 635-8030
FAX (416) 635-6588
TEL (603) 368-1299
TEL (03) 3225-8397

PILASTERS & SQUARE COLUMNS

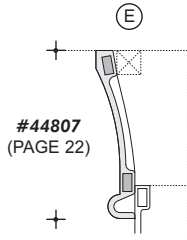

CHOICE OF
CAPITALS

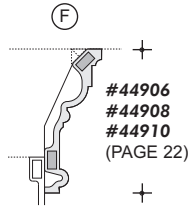

TYPE	A	D
#38307	7"	178
#38309	9"	229
#38310	10 1/2"	267
#38312	12"	304
#38314	14 1/2"	368
#38317	17"	432
#38319	19 1/2"	495

MIN. 2 1/4" 57
MAX. 5" 127

MIN. 3 1/2" 89
MAX. 6" 152



REMOVABLE PILASTER
(WITH LIGHT BLEEDS)

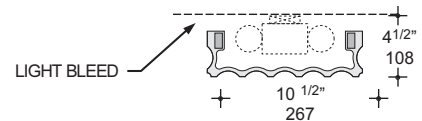
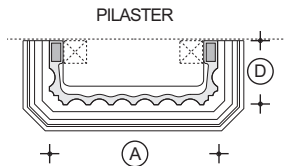
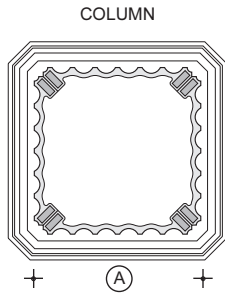
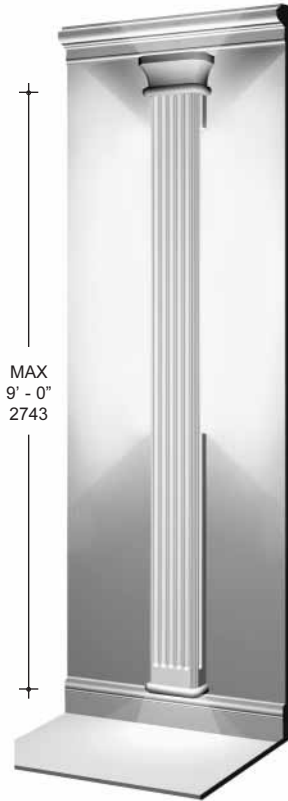
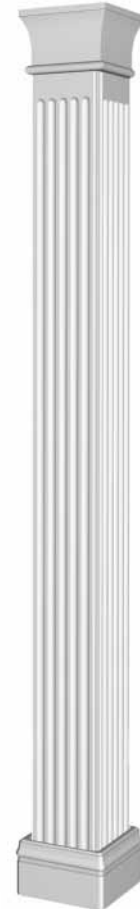
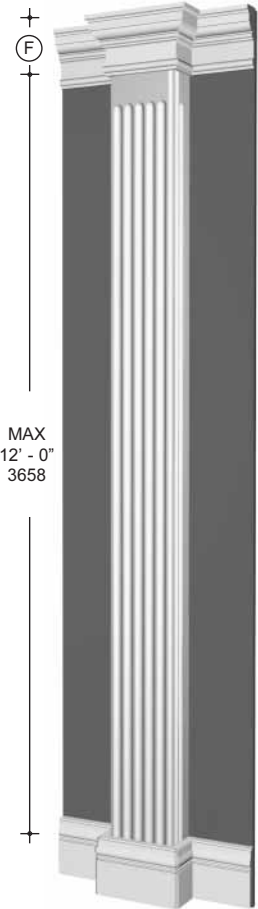

CHOICE OF
BASES #50406-12
(PAGE 37)

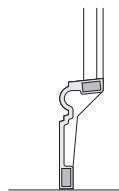
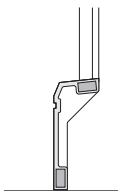

20 TORO ROAD
NORTH YORK, ONT, M3J 2A7
KUALA LUMPUR, MALAYSIA
TOKYO, JAPAN

TEL (416) 635-8030
FAX (416) 635-6588
TEL (603) 368-1299
TEL (03) 3225-8397

PILASTERS

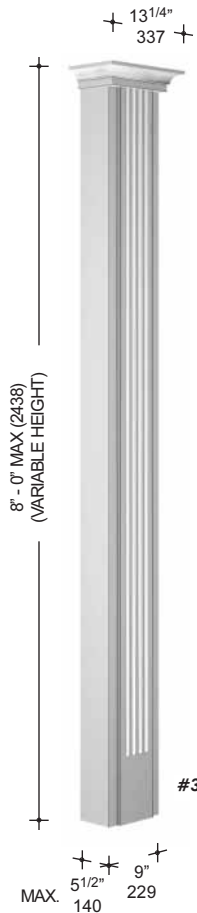

#30309

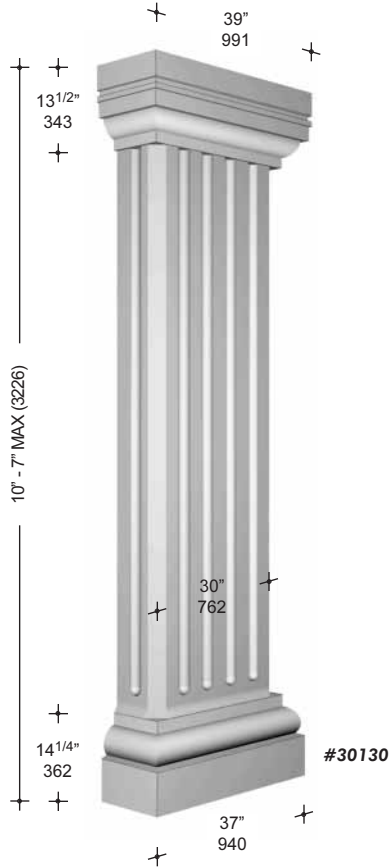

#30130

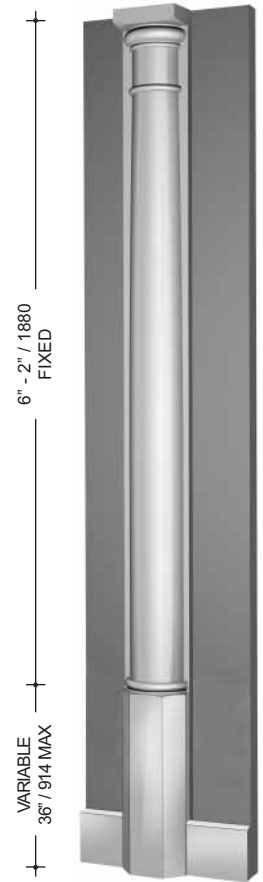
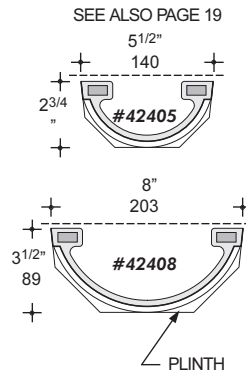

MOULDINGS

- #44810
- #44807

SEE PAGE 22

	#32506	#32509
(A)	6"	9"
	152	229
	MIN.	MIN.
	3 1/2"	5"
	89	127
(B)	MAX.	MAX.
	14"	22"
	356	559

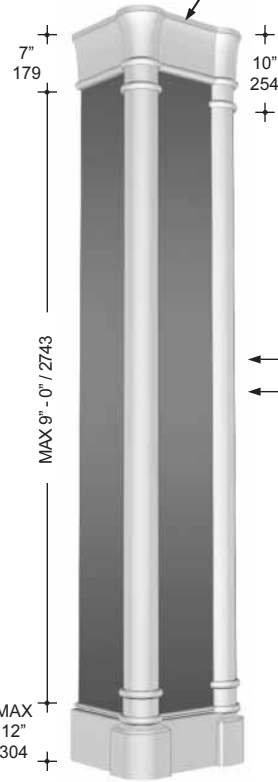
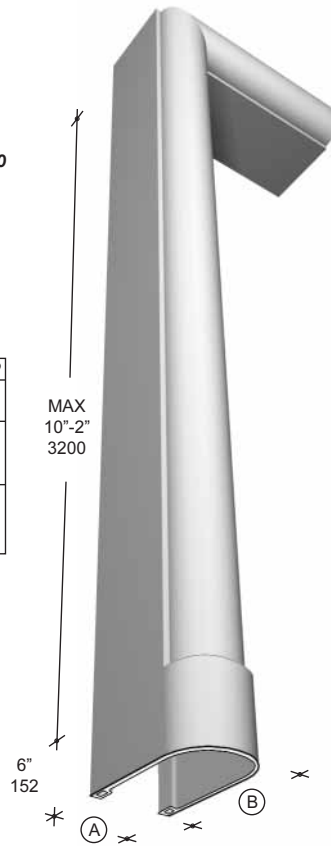

- #32704 " 4" / 102
- #32703 " 2 1/2" / 64

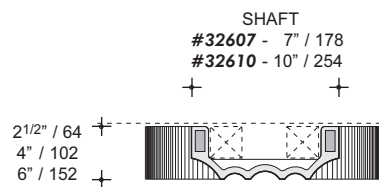
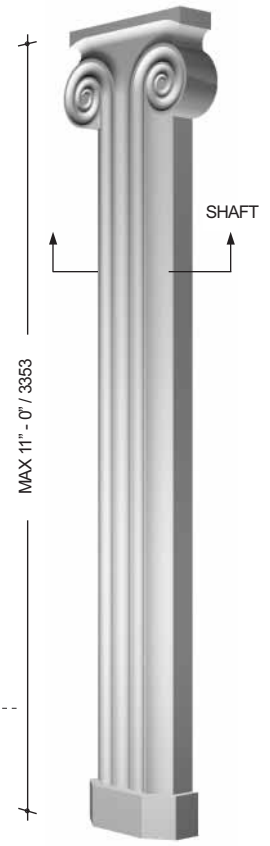
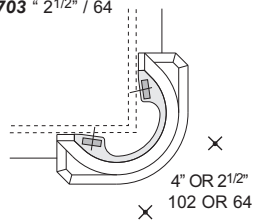

20 TORO ROAD
NORTH YORK, ONT, M3J 2A7
KUALA LUMPUR, MALAYSIA
TOKYO, JAPAN

TEL (416) 635-8030
FAX (416) 635-6588
TEL (603) 368-1299
TEL (03) 3225-8397

DOOR FRAMES

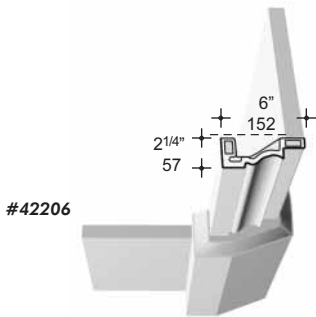
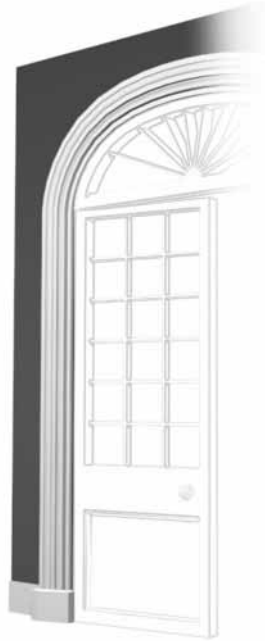

#42206

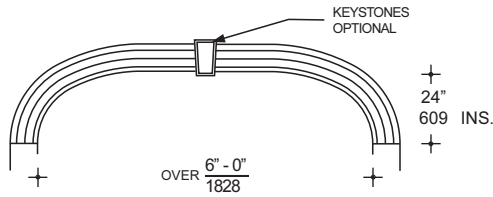

#42206
#42209
#42212



KEYSTONE

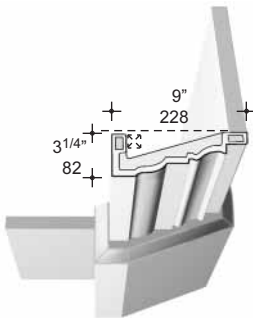

#42209

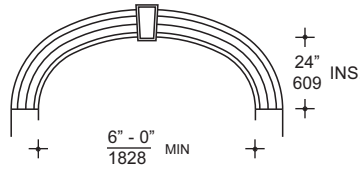

#42250

#42260

#42270

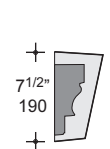

FOR #42206

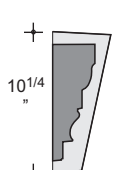

FOR #42209

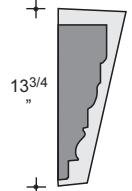

FOR #42212

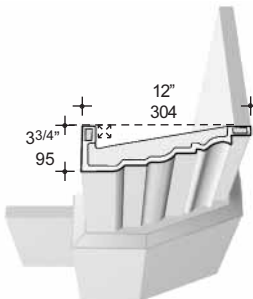

#42212

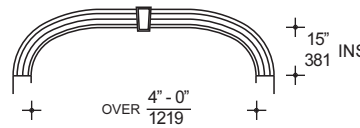

#42206
#42209

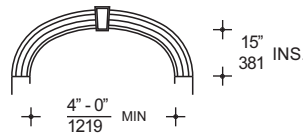

20 TORO ROAD
NORTH YORK, ONT, M3J 2A7
KUALA LUMPUR, MALAYSIA
TOKYO, JAPAN

TEL (416) 635-8030
FAX (416) 635-6588
TEL (603) 368-1299
TEL (03) 3225-8397

**NOT RECOMMENDED IN GYPSUM
UNLESS (FIELD) PAINTED WHITE**

DOOR FRAMES

WITH ROSETTES



#45304

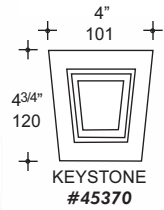
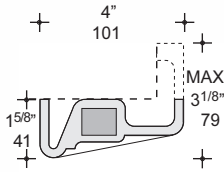

MAX $\frac{12''}{304}$



#44004

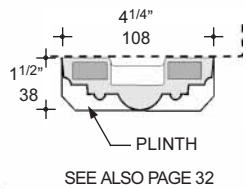

MAX $\frac{12''}{304}$

ROSETTES

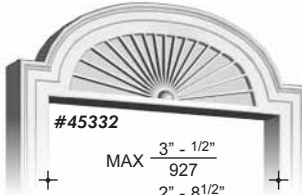
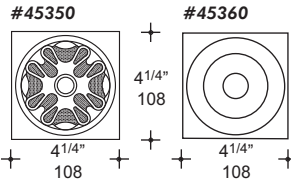

#45332

MAX $\frac{3'' - 1/2''}{927}$
MIN $\frac{2'' - 8 1/2''}{826}$

SEE PAGE 34

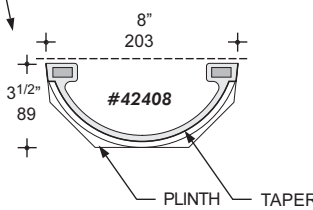
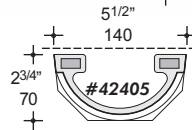
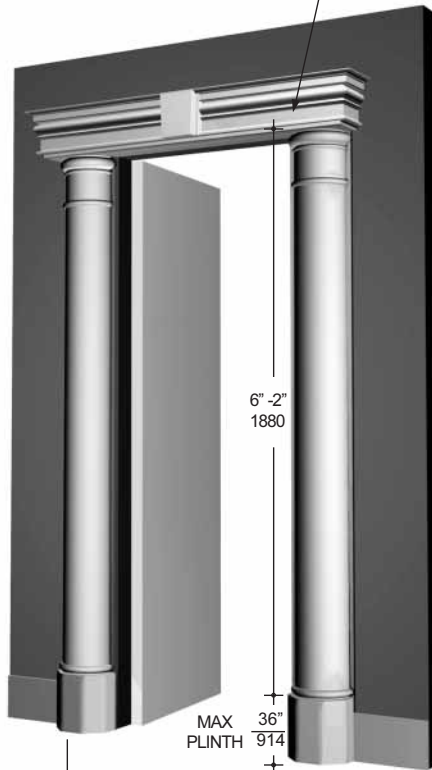

MAX $\frac{3'' - 1/2''}{927}$
MIN $\frac{2'' - 8 1/2''}{826}$

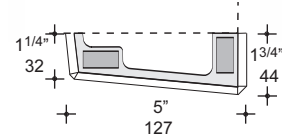
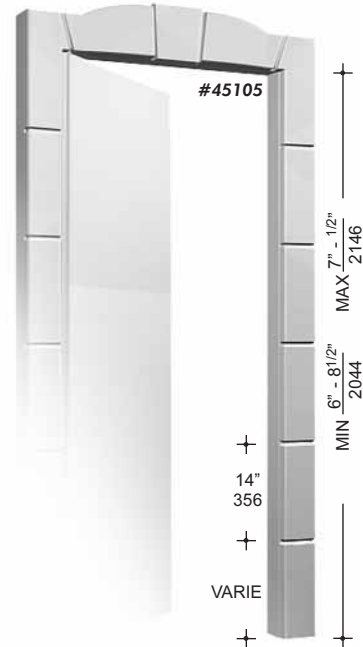

OPTIONAL

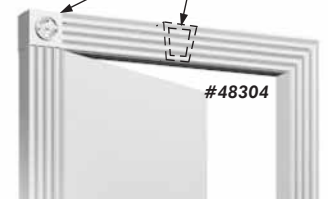

#48304

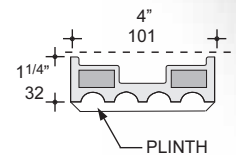

20 TORO ROAD
NORTH YORK, ONT, M3J 2A7
KUALA LUMPUR, MALAYSIA
TOKYO, JAPAN

TEL (416) 635-8030
FAX (416) 635-6588
TEL (603) 368-1299
TEL (03) 3225-8397

**NOT RECOMMENDED IN GYPSUM
UNLESS (FIELD) PAINTED WHITE**

MOULDINGS, LIGHT COVES & REFLECTORS

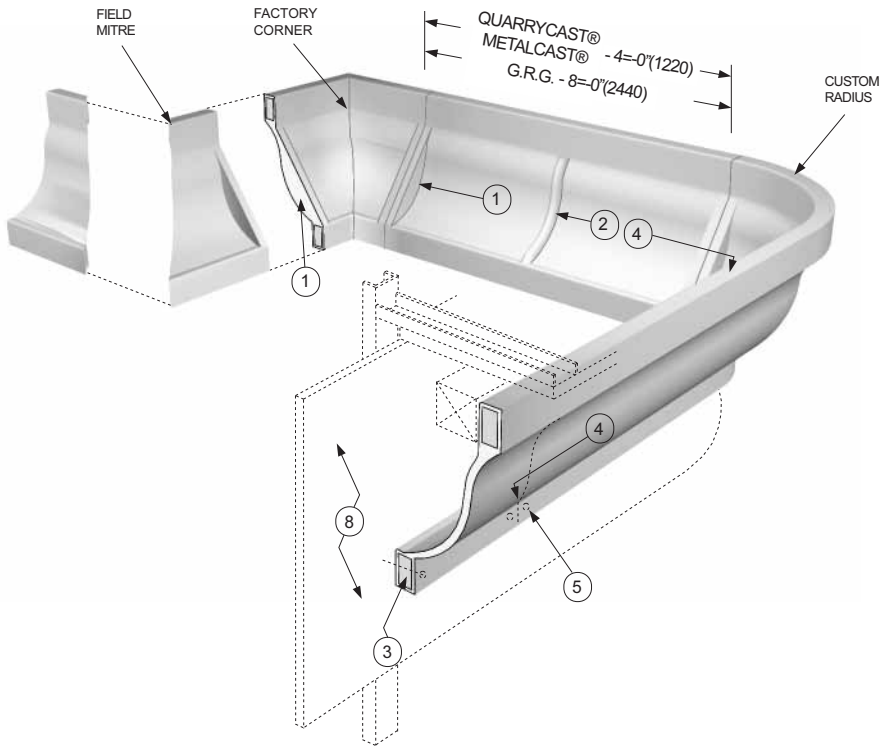

④ JOINT DETAIL

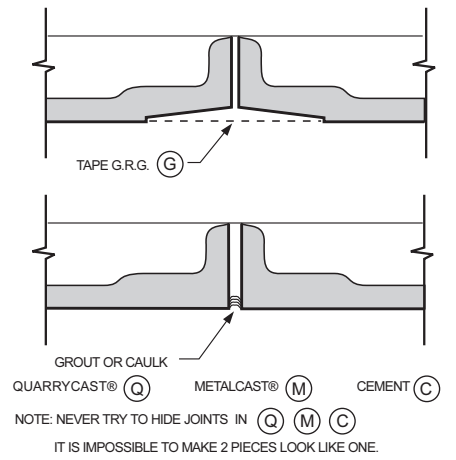

- ① END FLANGES OR GUSSETS FOR FIXT. SUPPORT
- ② INTERMEDIATE REINF. [FOR LARGE PARTS]
- ③ BUILT-IN REINF. [PLYWOOD, DRYWALL, ETC.]
- ④ JOINTS [SEE DET. ABOVE]
- ⑤ COUNTER SUNK FASTENERS [FILLED]
- ⑥ LIGHT COVE ALIGNMENT CLIPS [INSTALLER]
- ⑦ LIGHT FIXTURES
- ⑧ SUBSTRUCTURE & SUPPORTS [INSTALLER]

NOTE: CORNERS CAN BE FACTORY MADE OR FIELD MITERED BY THE INSTALLER. PLEASE SPECIFY.

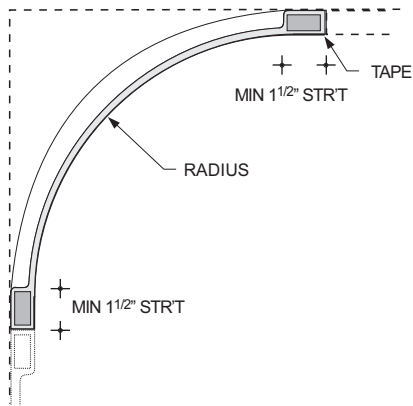

SERIES #77000
STANDARD REFLECTOR RADIUS
 4" (102) 6" (152) 8" (203)
 10" (254) 12" (305) 14" (356)
 16" (406) 18" (457) 20" (508)
 24" (610) 30" (762) 36" (914)
 42" (1067) 48" (1219)
 REFLECTORS AVAILABLE IN G.R.G. ONLY.

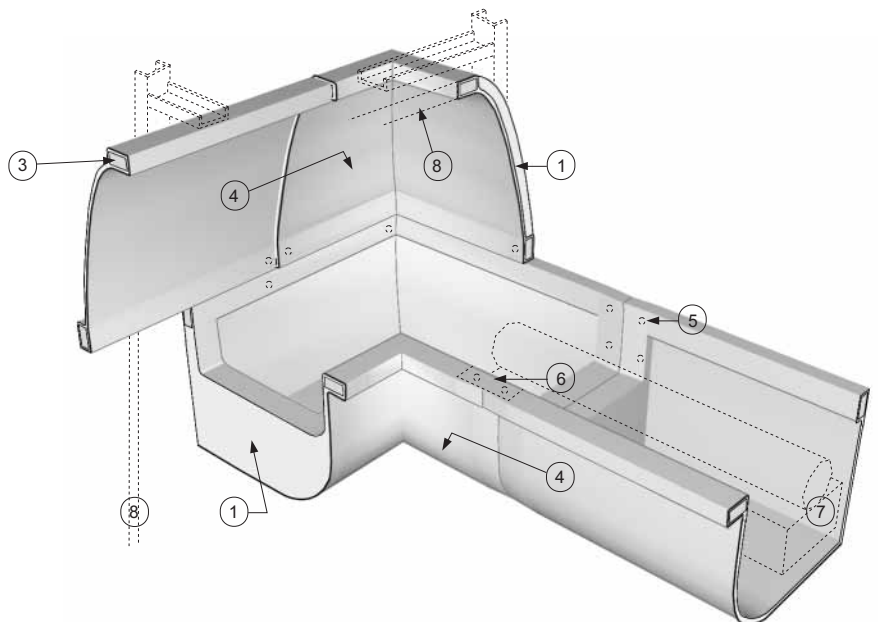

20 TORO ROAD
 NORTH YORK, ONT, M3J 2A7
 KUALA LUMPUR, MALAYSIA
 TOKYO, JAPAN

TEL (416) 635-8030
 FAX (416) 635-6588
 TEL (603) 368-1299
 TEL (03) 3225-8397

MOULDINGS

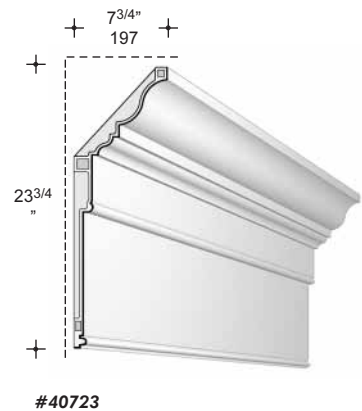
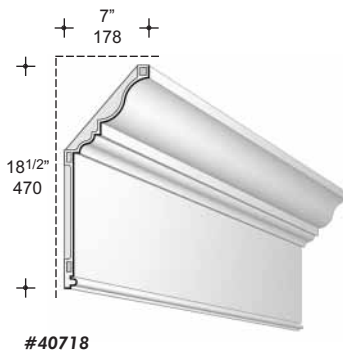
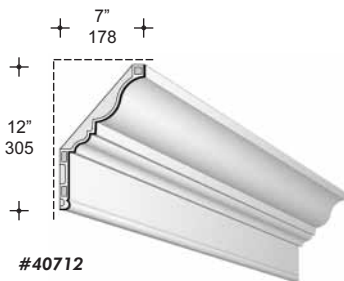
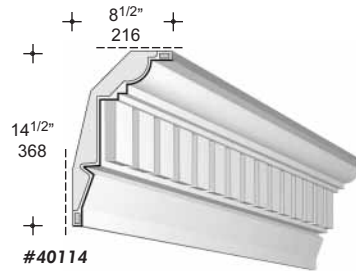
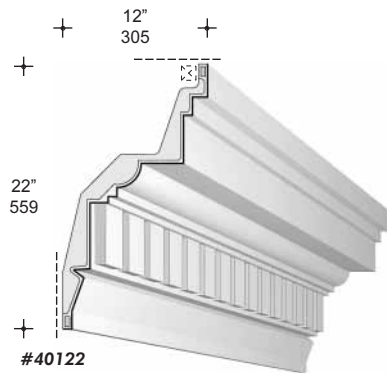
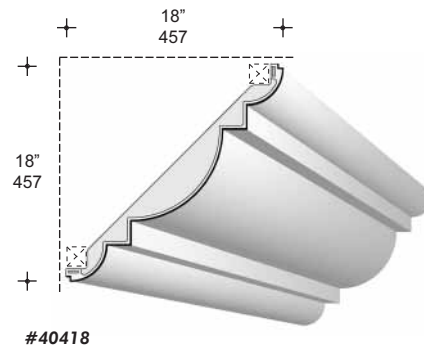
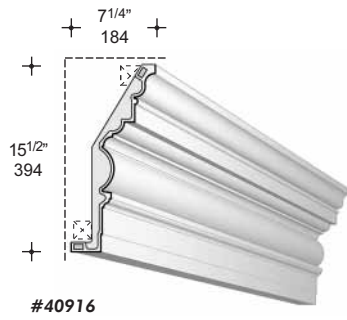
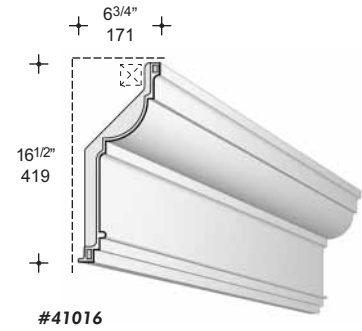
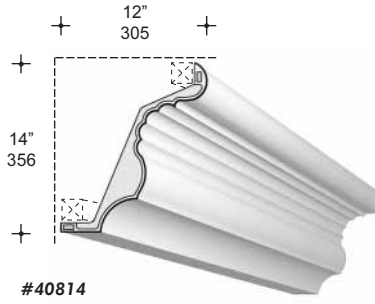
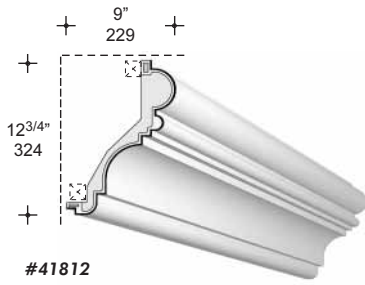

20 TORO ROAD
NORTH YORK, ONT, M3J 2A7
KUALA LUMPUR, MALAYSIA
TOKYO, JAPAN

TEL (416) 635-8030
FAX (416) 635-6588
TEL (603) 368-1299
TEL (03) 3225-8397

MOULDINGS

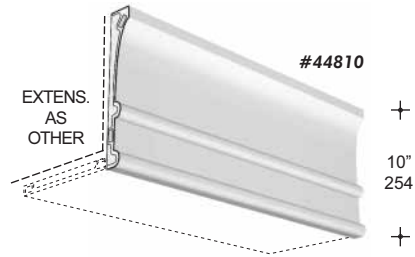
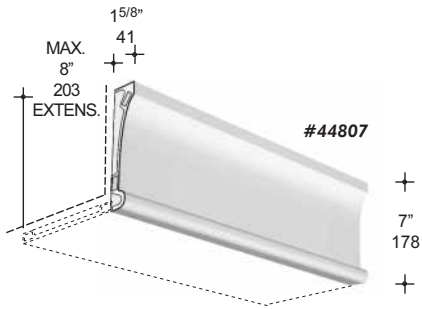
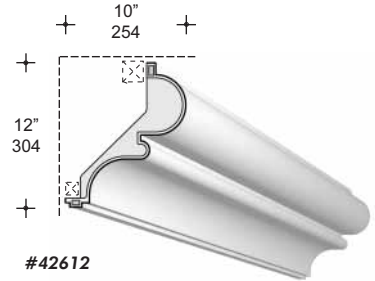
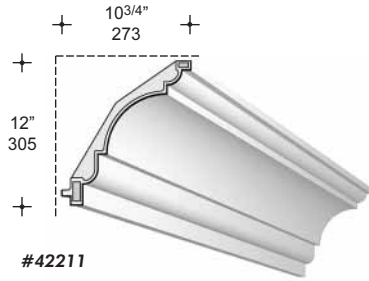
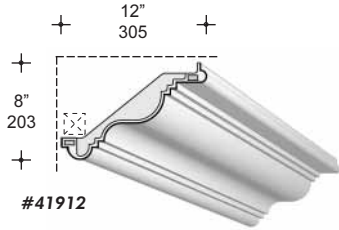

MATCHES "DORIC" CAPITALS

TYPE	A	B
#44906	5 3/8" 137	2 1/4" 57
#44908	8 1/8" 206	3 1/4" 83
#44910	10 3/4" 273	4 1/4" 41

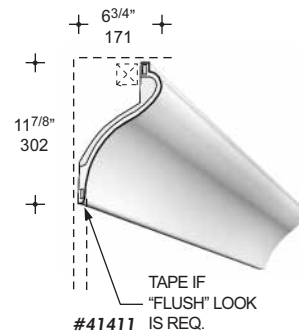
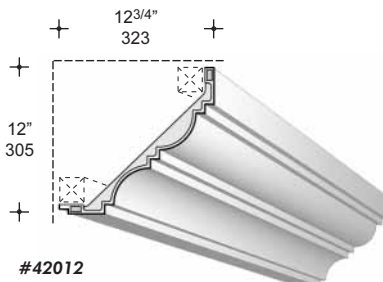
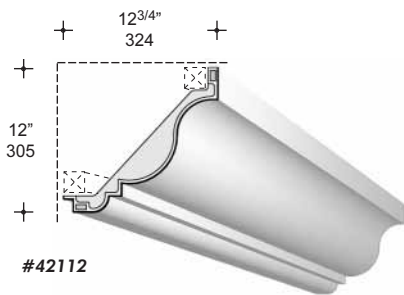
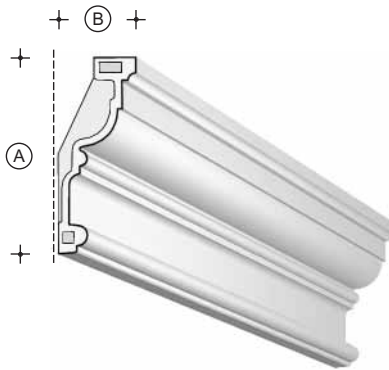

20 TORO ROAD
NORTH YORK, ONT, M3J 2A7
KUALA LUMPUR, MALAYSIA
TOKYO, JAPAN

TEL (416) 635-8030
FAX (416) 635-6588
TEL (603) 368-1299
TEL (03) 3225-8397

MOULDINGS

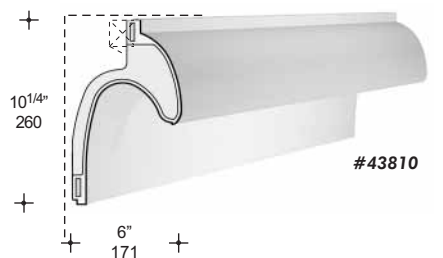
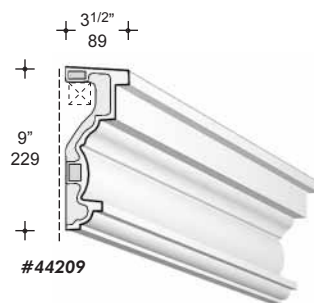
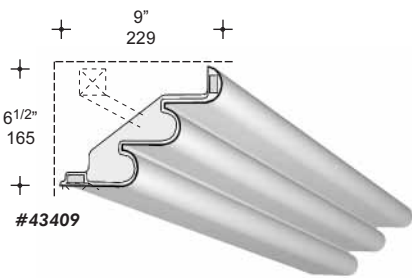
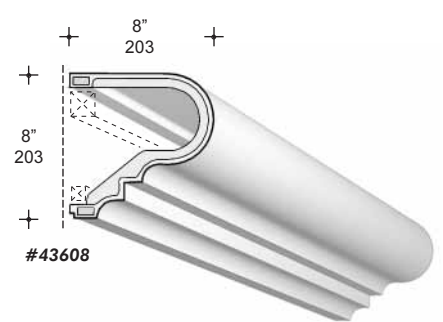
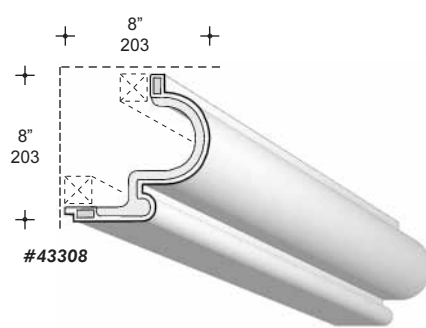
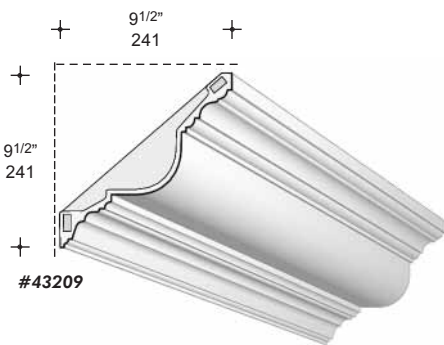
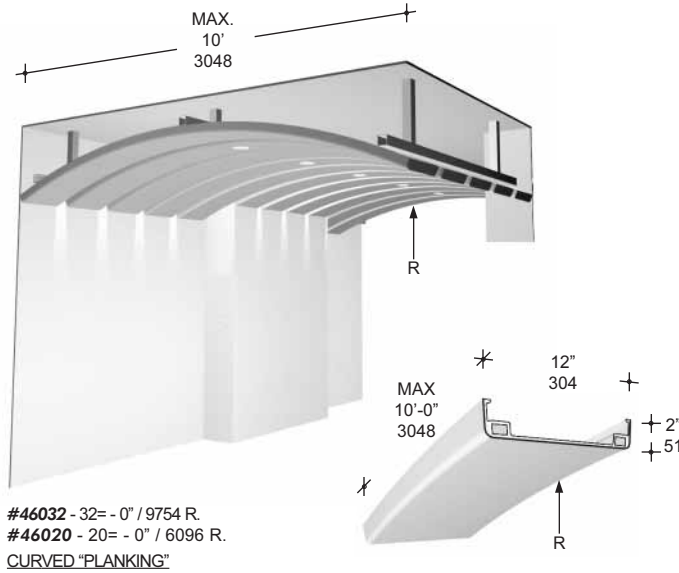
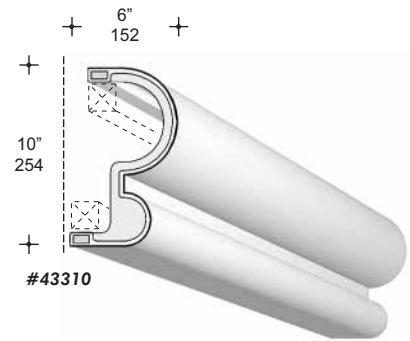
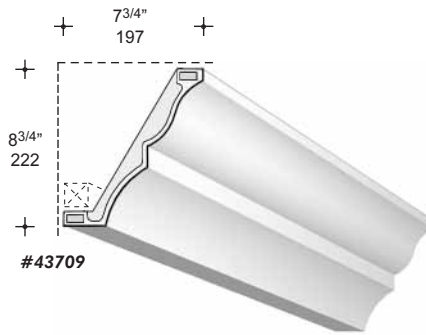
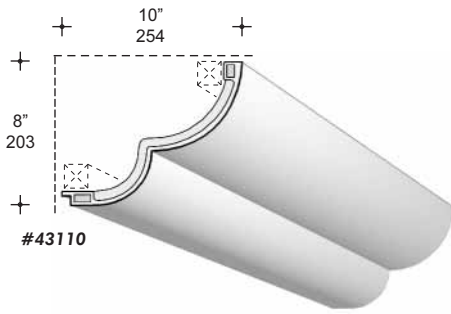

20 TORO ROAD
 NORTH YORK, ONT, M3J 2A7
 KUALA LUMPUR, MALAYSIA
 TOKYO, JAPAN

TEL (416) 635-8030
 FAX (416) 635-6588
 TEL (603) 368-1299
 TEL (03) 3225-8397

MOULDINGS & RAILINGS

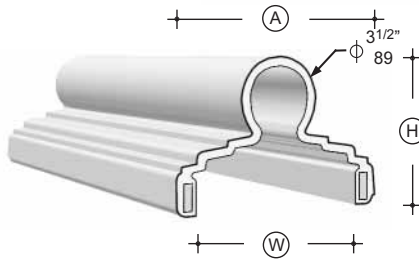
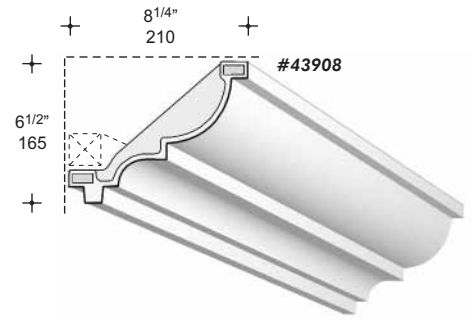
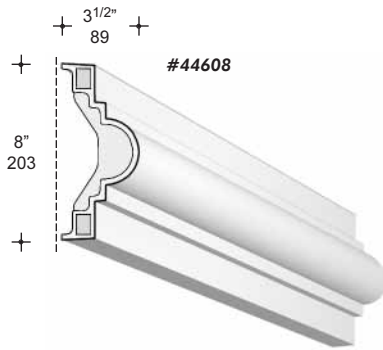
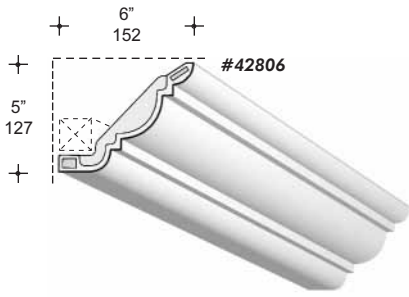

TYPE	A	H	W
#85106	6 1/2" 165	5 3/4" 146	5 5/8" 143
#85109	9 1/2" 241	6 3/8" 162	7 7/8" 200
#85111	11 1/2" 241	6 1/2" 165	9 7/8" 251

SEE ALSO PAGE 52

DETAILS MAY VARY FROM ILLUSTRATIONS

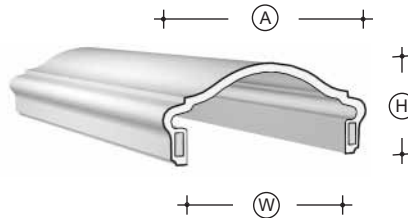

TYPE	A	H	W
#85204	4 3/8" 111	2 3/8" 60	2 1/8" 54
#85206	6 1/4" 159	2 3/8" 60	4 1/4" 108
#85207	7 1/4" 184	3" 76	5" 127
#85210	10 1/4" 260	4 5/8" 108	7 7/8" 200
#85212	12 3/4" 324	5 3/4" 165	9 7/8" 251

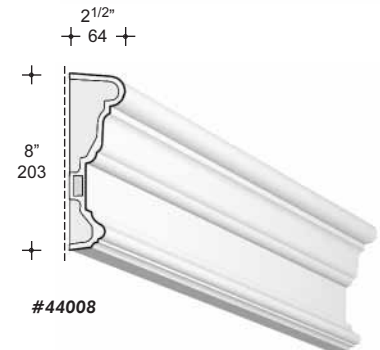
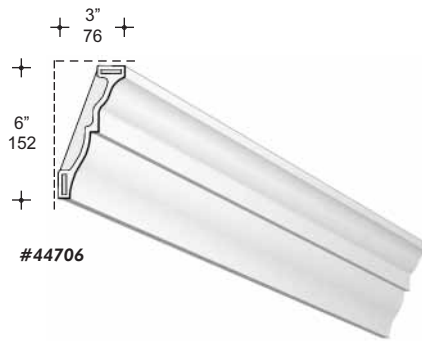
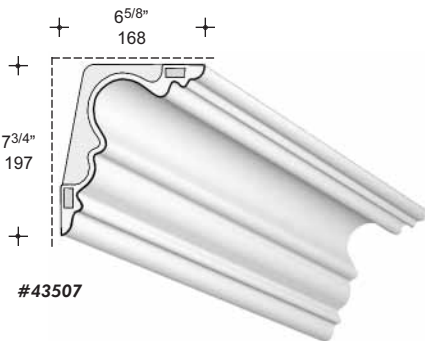
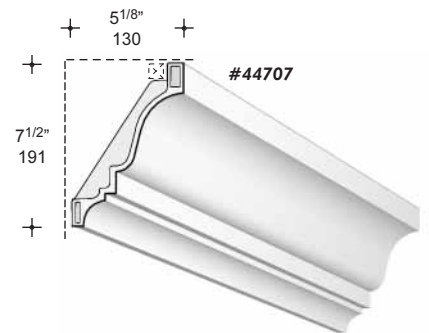
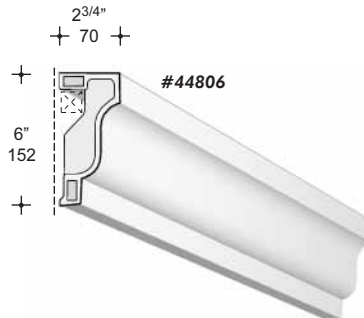
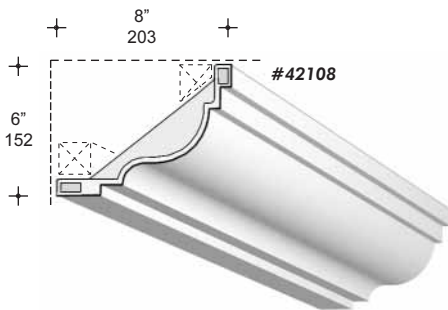

20 TORO ROAD
NORTH YORK, ONT, M3J 2A7
KUALA LUMPUR, MALAYSIA
TOKYO, JAPAN

TEL (416) 635-8030
FAX (416) 635-6588
TEL (603) 368-1299
TEL (03) 3225-8397

MOULDINGS

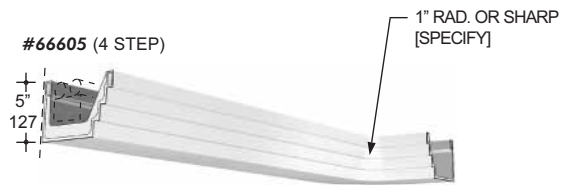
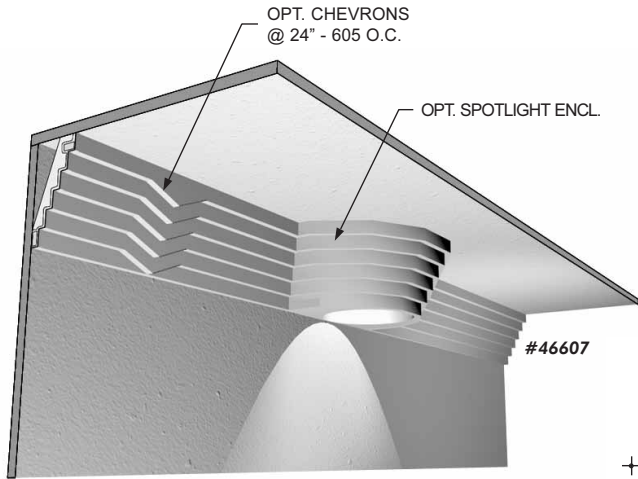

LIGHT COVE AVAILABLE IN 4, 5, 6 STEP

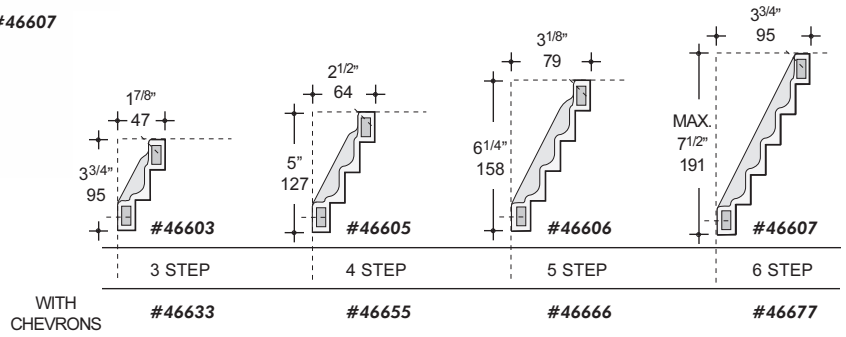

TYPE	A	B
#45907	7 1/2"	2 1/2"
	191	64
#45905	5 1/4"	2"
	133	51
#45904	4"	1 5/8"
	102	41
#45903	3 1/8"	1 1/4"
	79	32

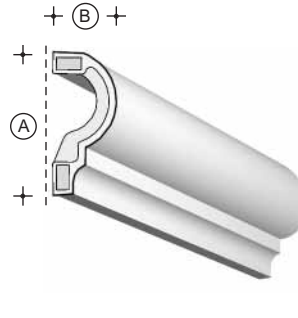
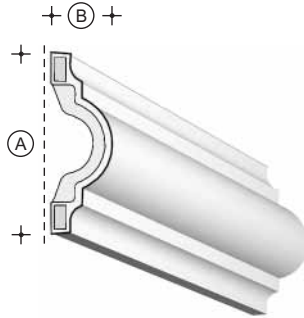

TYPE	A	B
#46005	5 7/8"	2 1/2"
	149	64
#46004	4 1/8"	2"
	105	51
#46003	3 1/16"	1 5/8"
	78	41
#46002	2 3/8"	1 1/4"
	60	32

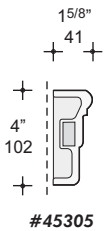

#45305

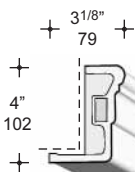

#45304

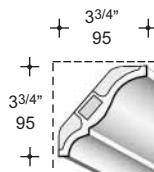

#45103

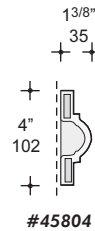

#45804

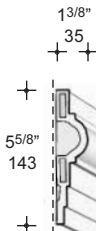

#45805

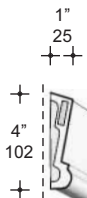

#45704

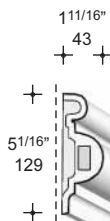

#45405

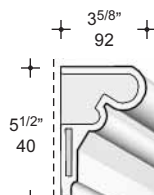

#45005

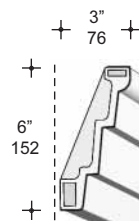

#40503



20 TORO ROAD
NORTH YORK, ONT, M3J 2A7
KUALA LUMPUR, MALAYSIA
TOKYO, JAPAN

TEL (416) 635-8030
FAX (416) 635-6588
TEL (603) 368-1299
TEL (03) 3225-8397

MOULDINGS

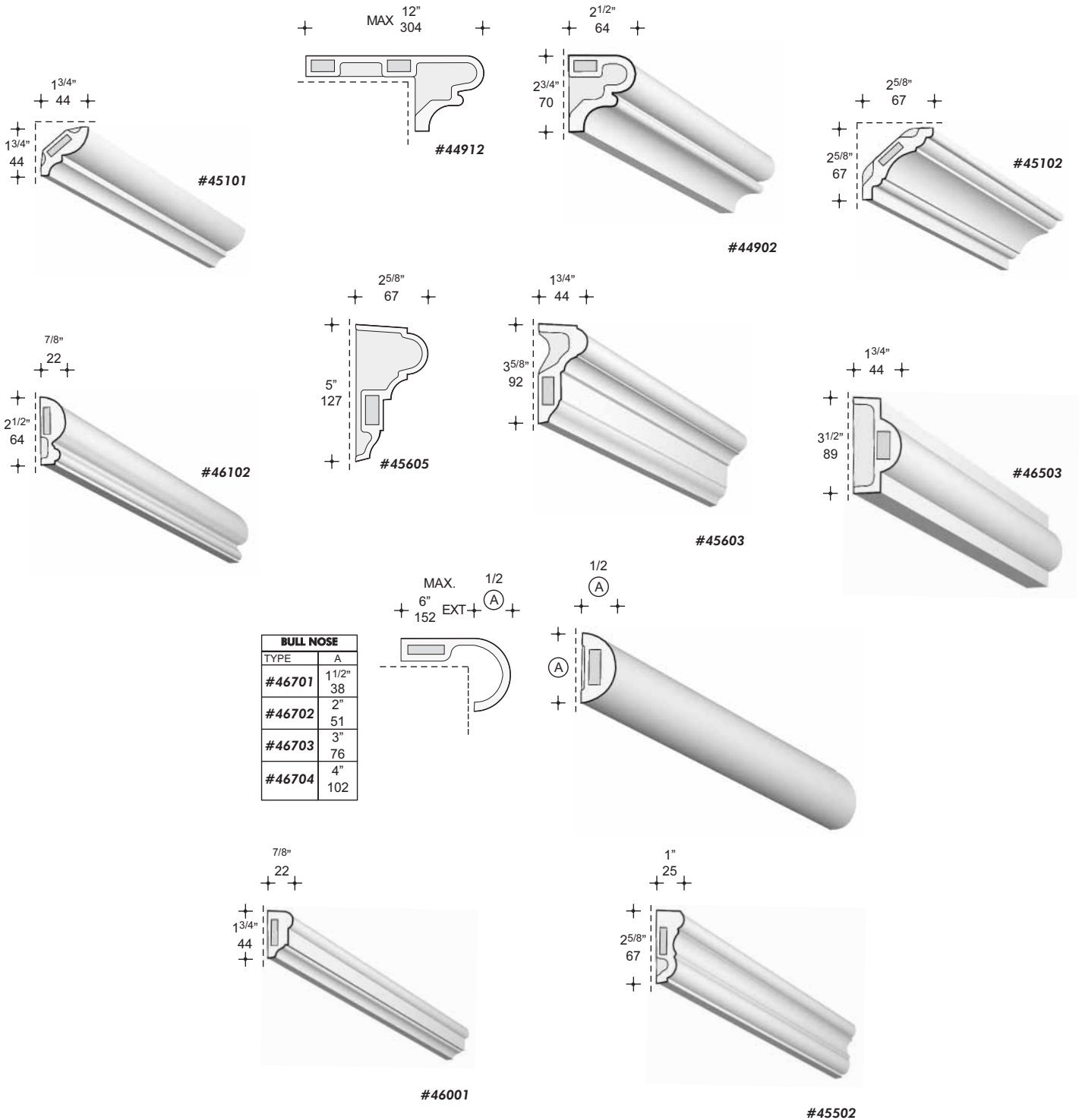

20 TORO ROAD
 NORTH YORK, ONT, M3J 2A7
 KUALA LUMPUR, MALAYSIA
 TOKYO, JAPAN

TEL (416) 635-8030
 FAX (416) 635-6588
 TEL (603) 368-1299
 TEL (03) 3225-8397

MOULDINGS

TRIM MOULDINGS

SEE STORE FRONT SKETCH ON PAGE #48 FOR APPLICATION OF THESE MOLDINGS.

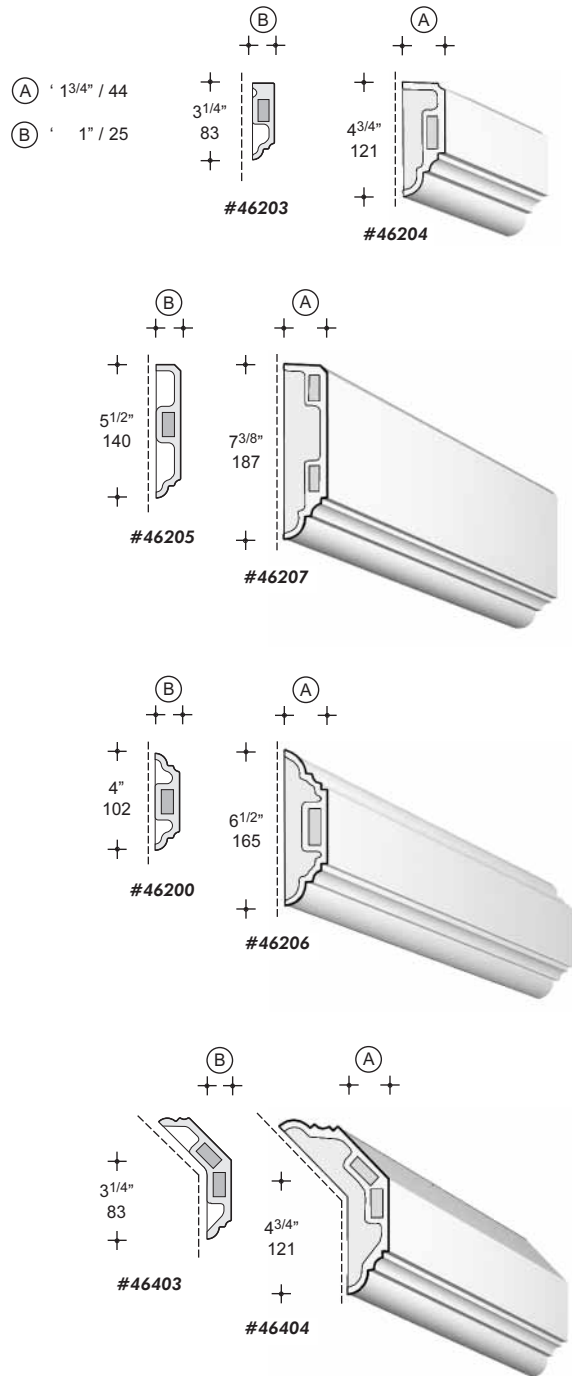
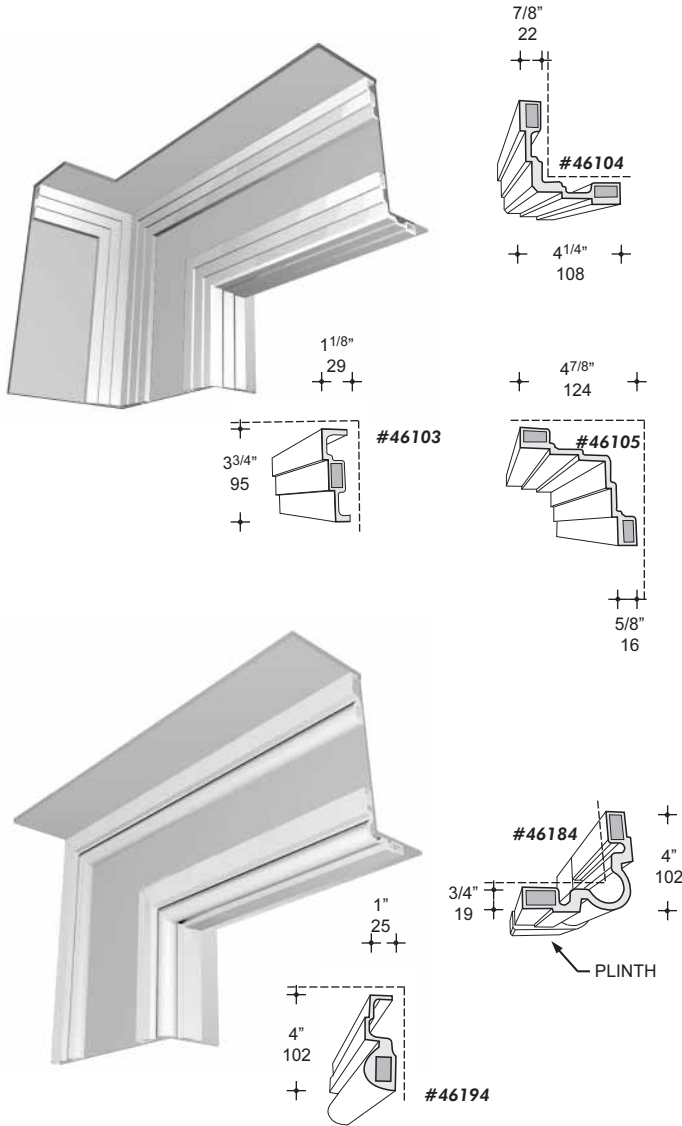

NOT RECOMMENDED AS DOOR FRAMES IN GYPSUM UNLESS (FIELD) PAINTED WHITE.

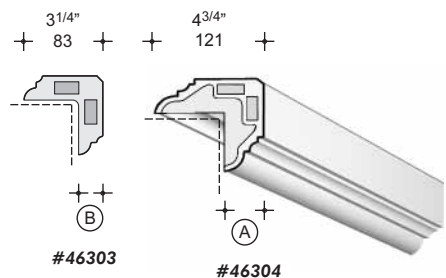

20 TORO ROAD
NORTH YORK, ONT, M3J 2A7
KUALA LUMPUR, MALAYSIA
TOKYO, JAPAN

TEL (416) 635-8030
FAX (416) 635-6588
TEL (603) 368-1299
TEL (03) 3225-8397

MOULDINGS

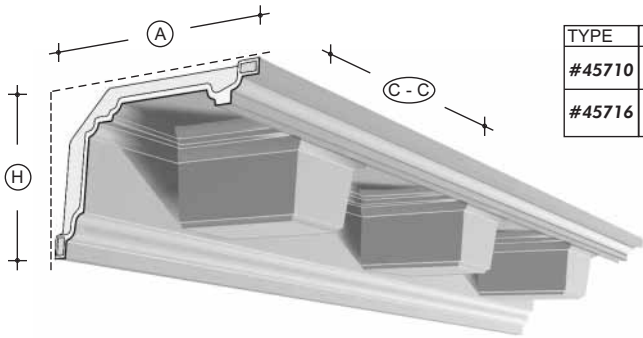

TYPE	A	H	C - C
#45710	10 1/4"	7 1/4"	16"
	260	184	406
#45716	16"	10 1/2"	24"
	406	267	610

TYPE	H	L
#45809	9"	19"
	229	483
#45813	13"	29"
	330	737

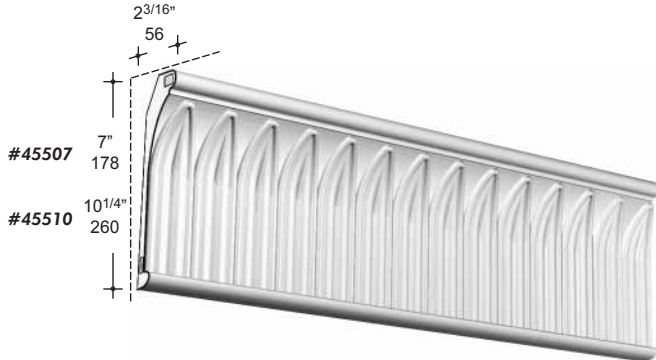
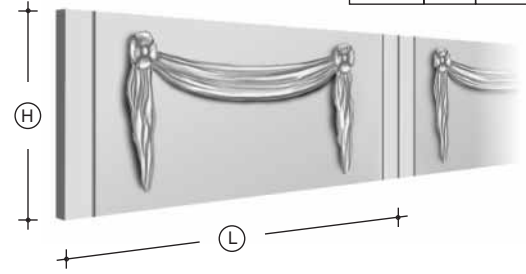

#45507
#45510

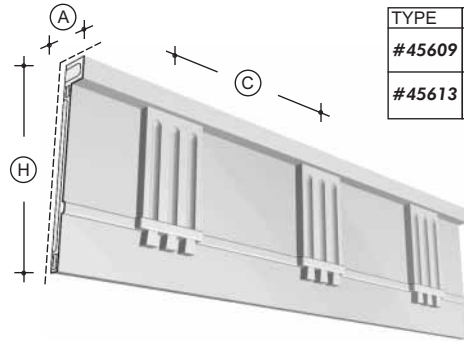

TYPE	H	A	C
#45609	9 1/2"	15/8"	12"
	241	41	304
#45613	13 1/2"	2"	16"
	343	51	406

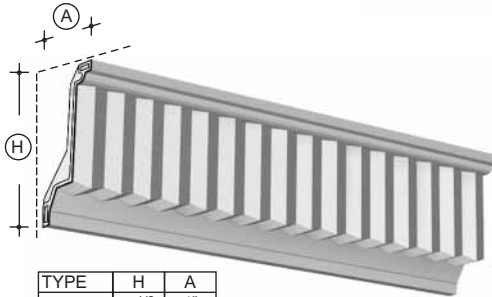

TYPE	H	A
#45410	10 1/2"	4"
	267	102
#45406	6"	3 1/2"
	152	89

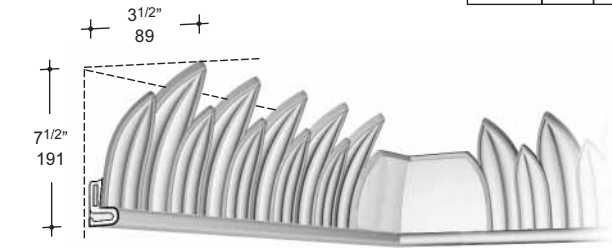

#45500

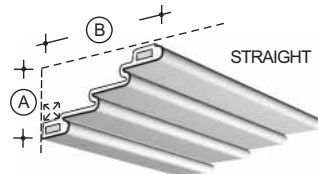
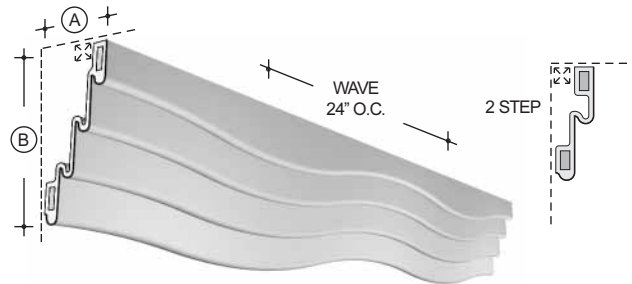
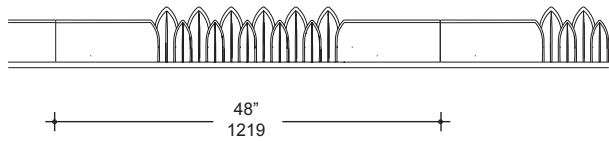

TYPE	4 STEP	
	B	A
#46609 STRAIGHT	9"	3"
	260	76
#46610 WAVE	10"	3"
	254	76
#46600 STRAIGHT	6"	2 1/2"
	152	64
AVAILABLE IN 2, 3 OR 4 STEP		



20 TORO ROAD
NORTH YORK, ONT, M3J 2A7
KUALA LUMPUR, MALAYSIA
TOKYO, JAPAN

TEL (416) 635-8030
FAX (416) 635-6588
TEL (603) 368-1299
TEL (03) 3225-8397

MOULDINGS

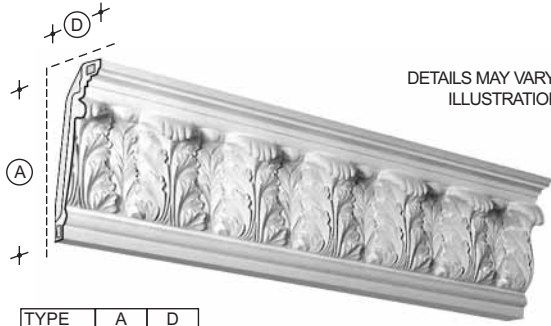

DETAILS MAY VARY FROM ILLUSTRATIONS

TYPE	A	D
#46808	8 ⁵ / ₈ " 219	4 ¹ / ₂ " 108
#46805	5 ¹ / ₄ " 133	2 ⁵ / ₈ " 67
#46803	3 ³ / ₄ " 95	2 ⁵ / ₈ " 67



TYPE	H
#46506	6" 152
#46512	12" 304
#46529	29 ¹ / ₂ " 749



#46824

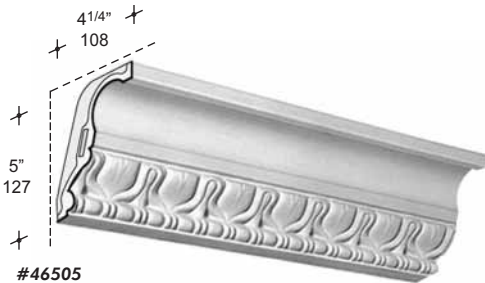

#46505

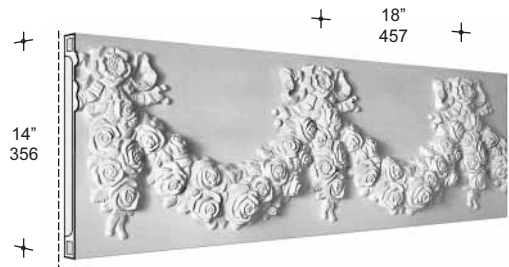

#45814

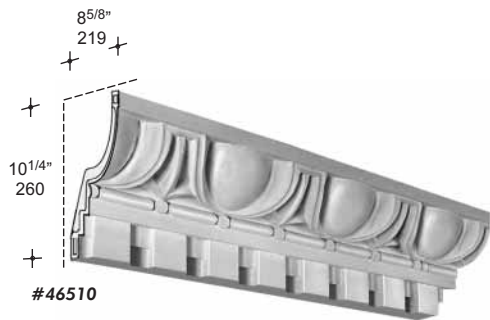

#46510



#46814



20 TORO ROAD
NORTH YORK, ONT, M3J 2A7
KUALA LUMPUR, MALAYSIA
TOKYO, JAPAN

TEL (416) 635-8030
FAX (416) 635-6588
TEL (603) 368-1299
TEL (03) 3225-8397

MOULDINGS [DENTIL]

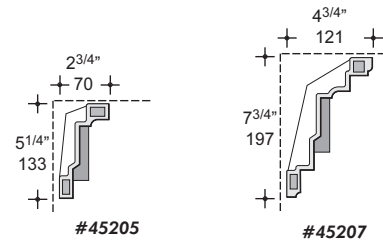
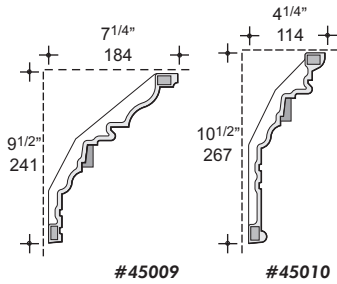
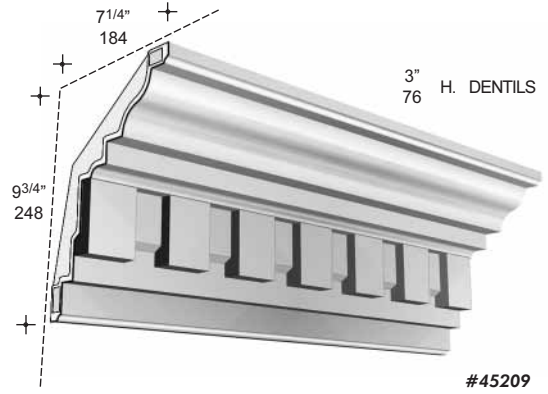
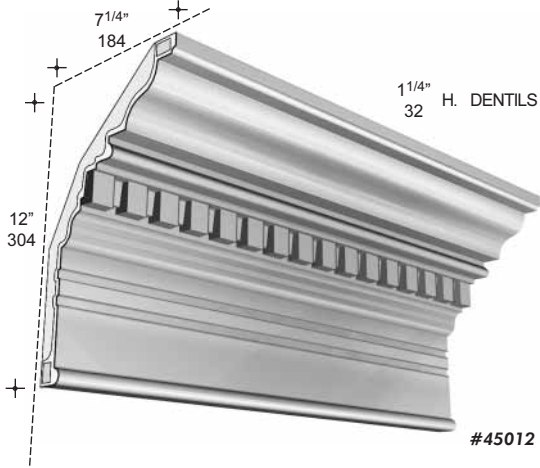

SEE PG. 41 FOR LIGHT COVES

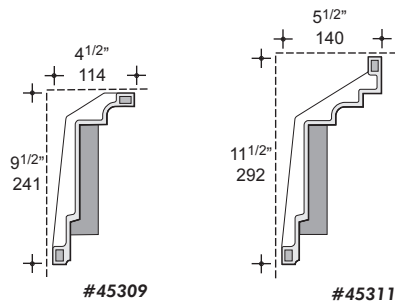
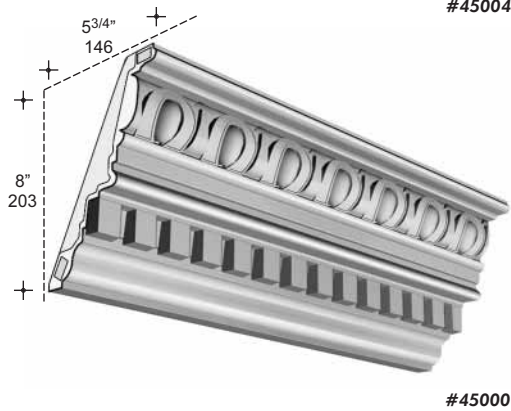
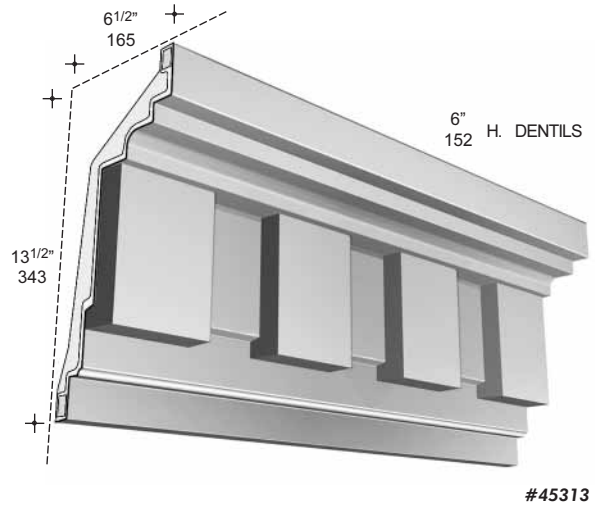
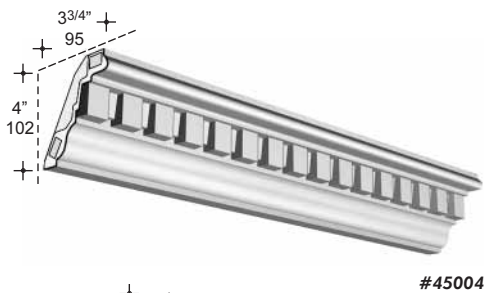
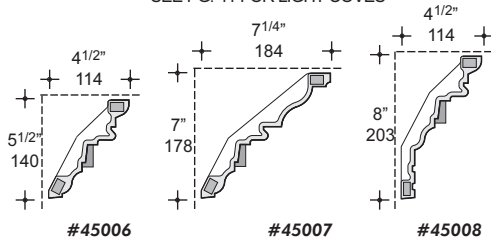

20 TORO ROAD
NORTH YORK, ONT, M3J 2A7
KUALA LUMPUR, MALAYSIA
TOKYO, JAPAN

TEL (416) 635-8030
FAX (416) 635-6588
TEL (603) 368-1299
TEL (03) 3225-8397

MOULDINGS

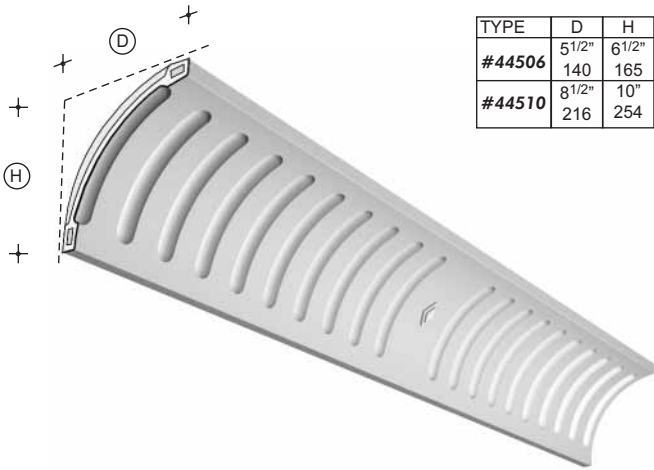

TYPE	D	H
#44506	5 1/2"	6 1/2"
	140	165
#44510	8 1/2"	10"
	216	254

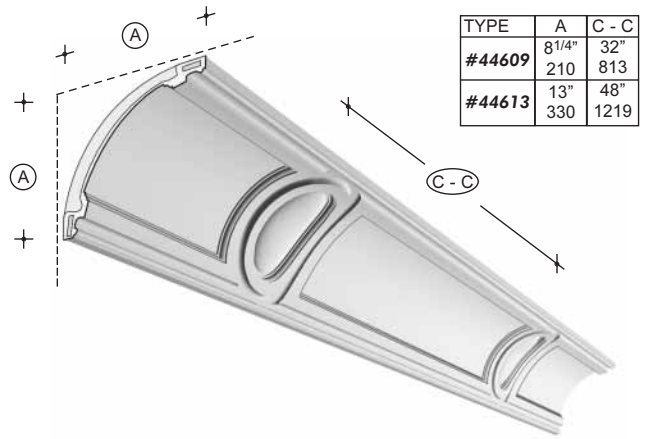

TYPE	A	C - C
#44609	8 1/4"	32"
	210	813
#44613	13"	48"
	330	1219

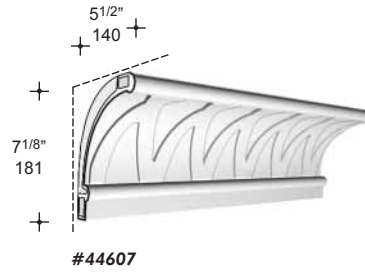
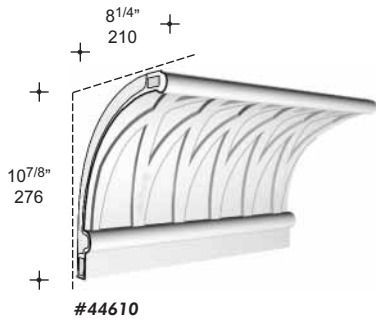

TYPE	#44701	#44703	#44705
(H)	1 1/2" 38	3 1/8" 79	5 7/8" 149
(A)	5/8" 16	7/8" 22	1 1/8" 29

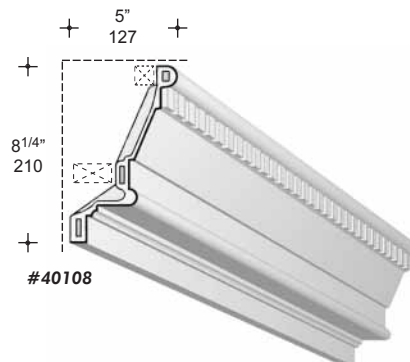
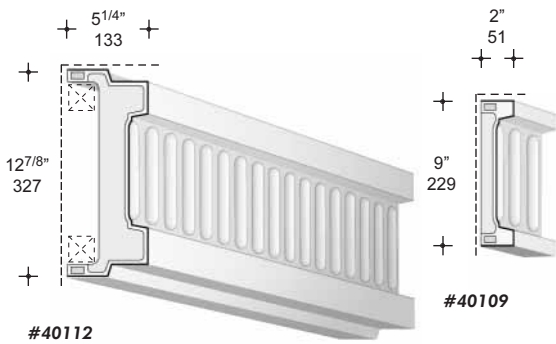

20 TORO ROAD
NORTH YORK, ONT, M3J 2A7
KUALA LUMPUR, MALAYSIA
TOKYO, JAPAN

TEL (416) 635-8030
FAX (416) 635-6588
TEL (603) 368-1299
TEL (03) 3225-8397

MOULDINGS

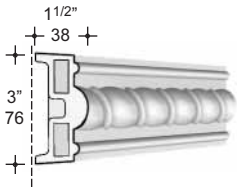

#44003

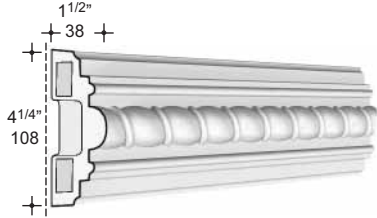

#44004

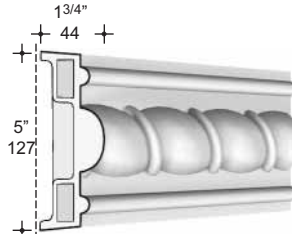

#44005

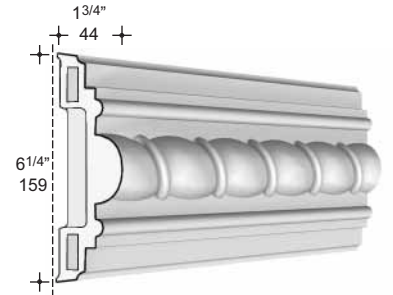

#44006

TYPE	A	B
#44203	3" 76	1" 25
#44205	5" 127	1 3/16" 30
#44208	8" 203	1 5/8" 41

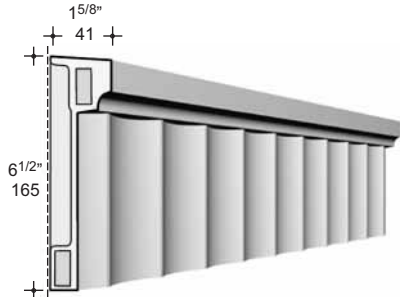
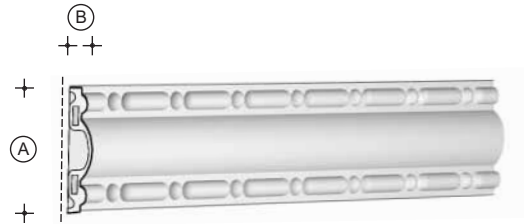

#44106

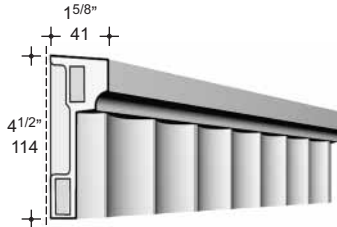

#44104

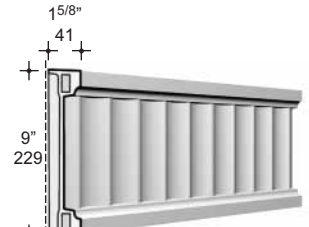

#44109

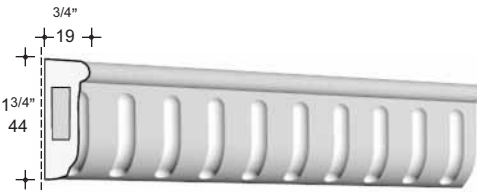

#44501

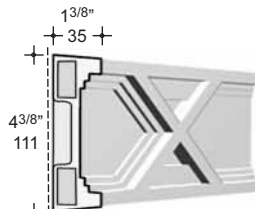

#44304

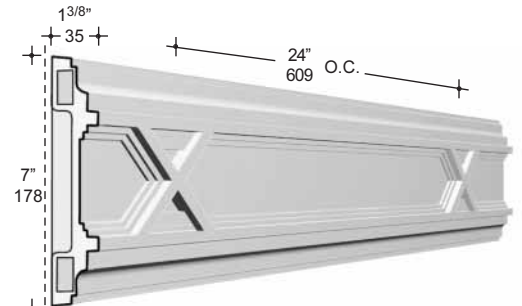

#44307



#44504

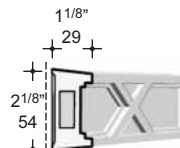

#44402

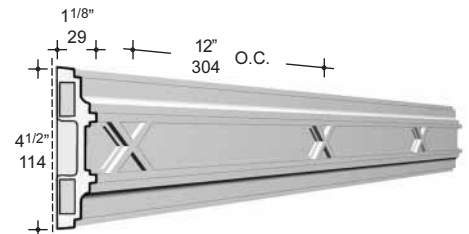

#44404



20 TORO ROAD
NORTH YORK, ONT, M3J 2A7
KUALA LUMPUR, MALAYSIA
TOKYO, JAPAN

TEL (416) 635-8030
FAX (416) 635-6588
TEL (603) 368-1299
TEL (03) 3225-8397

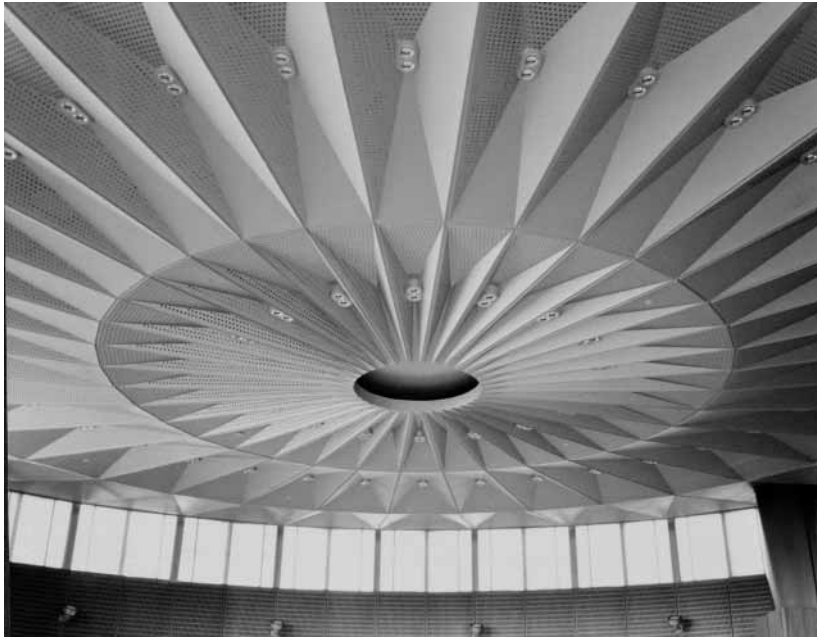

PROJECTS WITH CUSTOM MADE ELEMENTS.
[NOT AVAILABLE OR SHOWN IN THIS CATALOG]



20 TORO ROAD
NORTH YORK, ONT, M3J 2A7
KUALA LUMPUR, MALAYSIA
TOKYO, JAPAN

TEL (416) 635-8030
FAX (416) 635-6588
TEL (603) 368-1299
TEL (03) 3225-8397

PEDIMENTS & LIN-

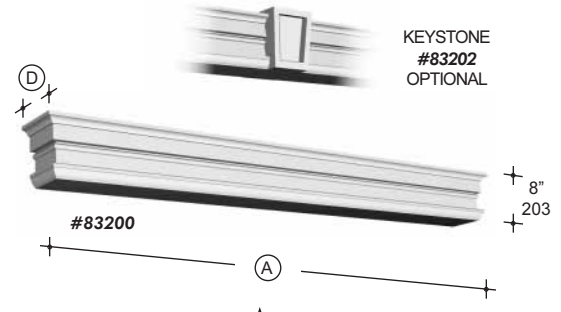
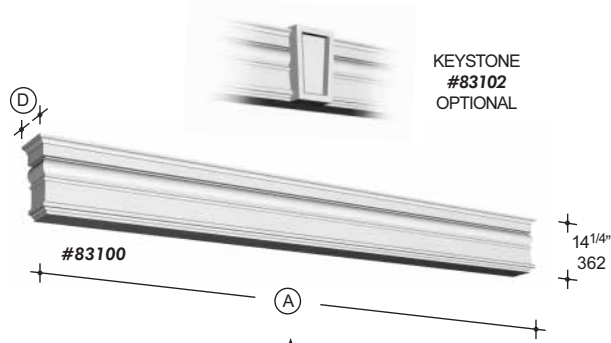
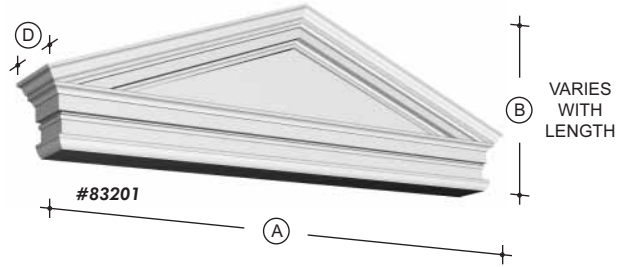
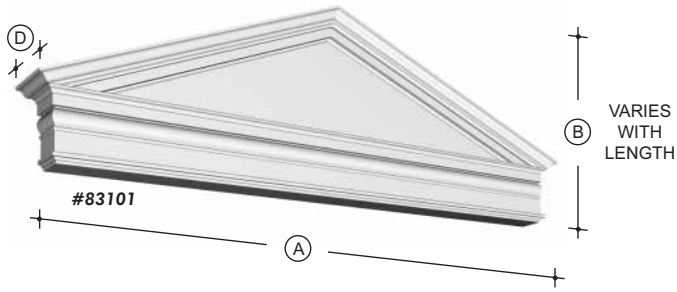

		(A)	(B)	(D)
#83101	MAX	9' - 0" / 2743	2' - 9 ⁵ / ₈ " / 854	9" OR 7"
	MIN	6' - 6" / 1981	2' - 3 ⁵ / ₈ " / 702	229 OR 178
#83100	MAX	8' - 6" / 2591		8 ¹ / ₄ " OR 6 ¹ / ₄ "
	MIN	4' - 6" / 1372		210 OR 159

		(A)	(B)	(D)
#83201	MAX	7' - 0" / 2134	2' - 1 ³ / ₈ " / 644	7 ⁵ / ₈ " OR 5 ⁵ / ₈ "
	MIN	4' - 0" / 1219	1' - 6 ⁵ / ₈ " / 473	194 OR 143
#83200	MAX	8' - 0" / 2438		6 ³ / ₈ " OR 4 ³ / ₈ "
	MIN	3' - 8" / 1118		162 OR 111

HALLWAY BEAMS

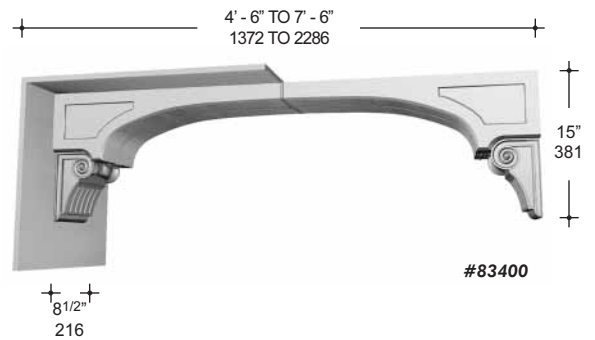
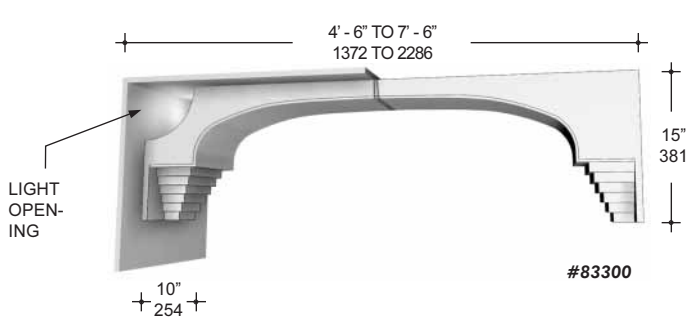

BEAMS

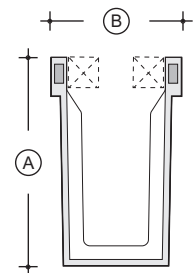
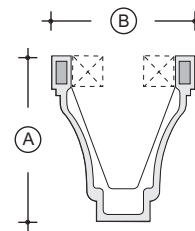

TYPE	A	B
#83903	3 ¹ / ₂ "	4"
	406	102
#83906	6"	5"
	152	127
#83908	8"	7"
	203	178

TYPE	A	B
#83905	5"	4"
	127	102
#83907	7 ¹ / ₂ "	5"
	191	127
#83909	9 ¹ / ₂ "	7"
	241	178



20 TORO ROAD
NORTH YORK, ONT, M3J 2A7
KUALA LUMPUR, MALAYSIA
TOKYO, JAPAN

TEL (416) 635-8030
FAX (416) 635-6588
TEL (603) 368-1299
TEL (03) 3225-8397

BRACKETS

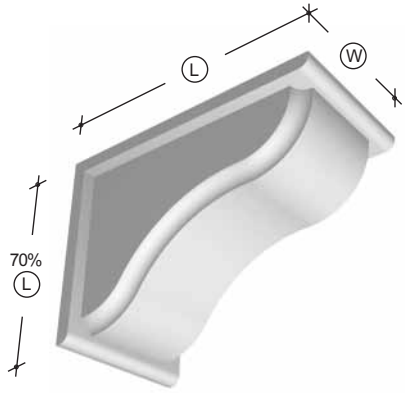

TYPE	L	W
#81610	10" 254	5 1/4" 133
#81615	15" 381	7 1/2" 191
#81620	20" 508	9 1/2" 241
#81624	25" 635	11 1/2" 292

TYPE	L	W
#81712	12" 304	4" 102
#81717	17" 432	5 1/8" 130
#81723	23" 584	6 1/2" 165
#81729	29" 737	8" 203
#81736	36" 914	8" 203

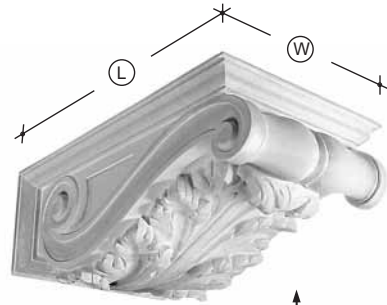

TYPE	L	W
#81811	11" 279	5" 127
#81816	16" 406	7" 178
#81822	22 3/4" 578	10" 254
#81826	26" 660	16 1/2" 419
#81834	34" 864	16 1/2" 419

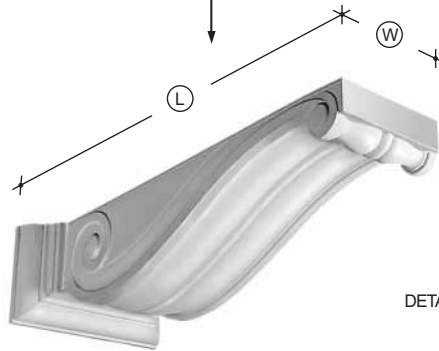

DETAILS MAY VARY FROM ILLUSTRATIONS

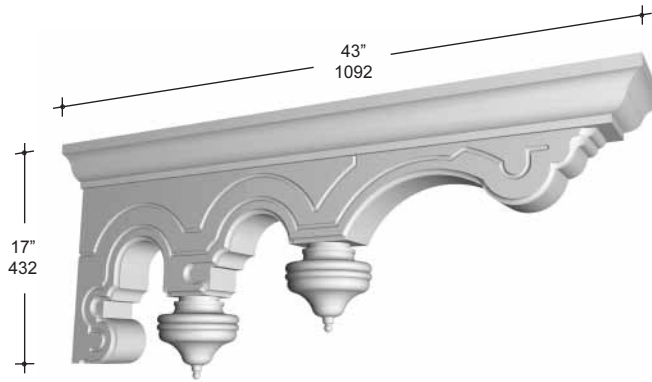

#81743

BASEBOARDS

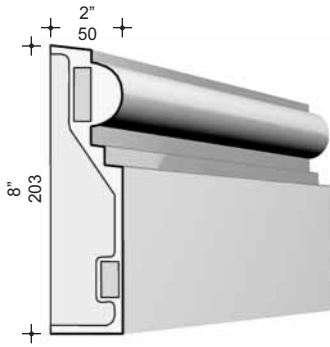

TYPE	HIGH
#50106	6" 152
#50108	8" 203
#50110	10" 254
#50112	12" 304

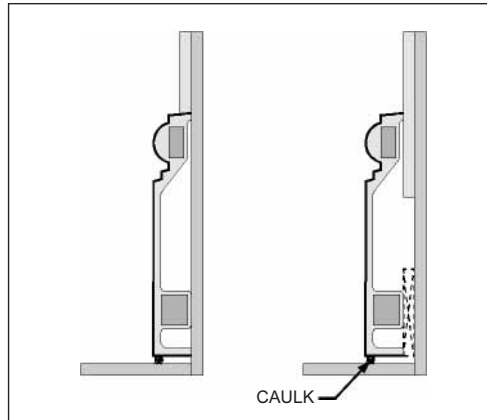

CONDITIONS WITH QUARRYCAST® VENEER

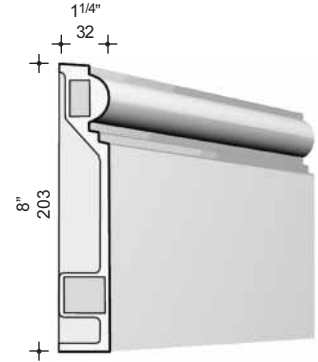

TYPE	HIGH
#50406	6" 152
#50408	8" 203
#50410	10" 254
#50412	12" 304

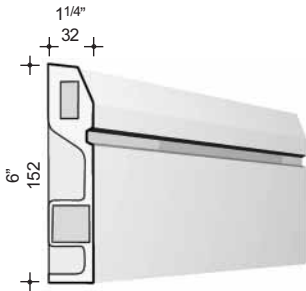

TYPE	HIGH
#50606	6" 152
#50608	8" 203
#50610	10" 254
#50612	12" 304

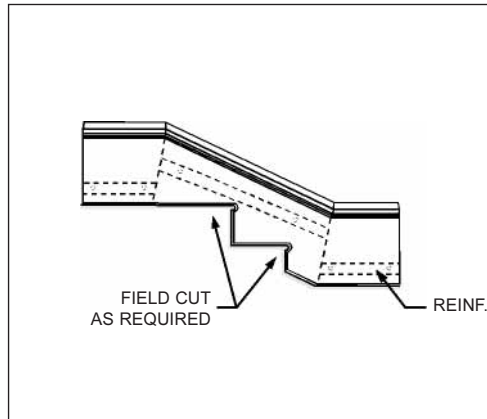

CONDITIONS AT STAIRS - FIELD CUT

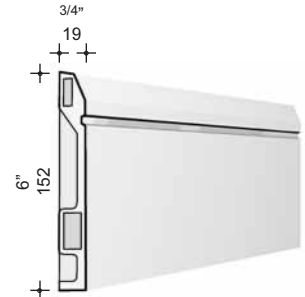

TYPE	HIGH
#50704	4" 102
#50706	6" 152
#50708	8" 203
#50710	10" 254

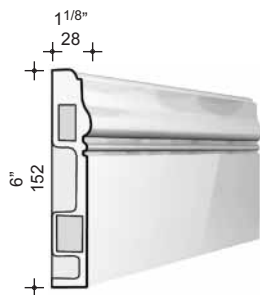

TYPE	HIGH
#50204	4" 102
#50206	6" 152
#50208	8" 203
#50209	9" 228



FACTORY CORNER / END CAP WITH BEVEL TO MINIMIZE DAMAGE

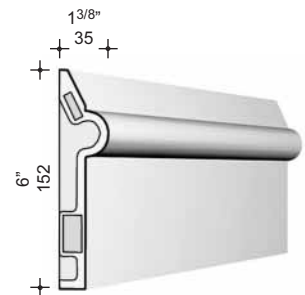

TYPE	HIGH
#50304	4" 102
#50305	5" 127
#50306	6" 152
#50307	7" 178



20 TORO ROAD
NORTH YORK, ONT, M3J 2A7
KUALA LUMPUR, MALAYSIA
TOKYO, JAPAN

TEL (416) 635-8030
FAX (416) 635-6588
TEL (603) 368-1299
TEL (03) 3225-8397

NOTE: BASEBOARDS ARE AVAILABLE IN QUARRYCAST® ONLY.

LIGHT COVES

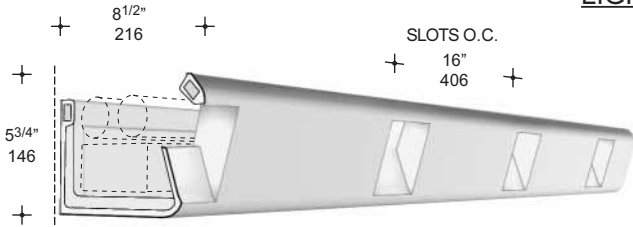

#62008
SLOTS HAVE WHITE PLEXIGLAS FOR LIGHT BLEED OR CAN BE CLOSED.

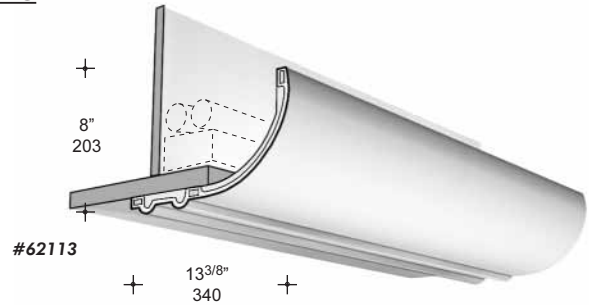

#62113

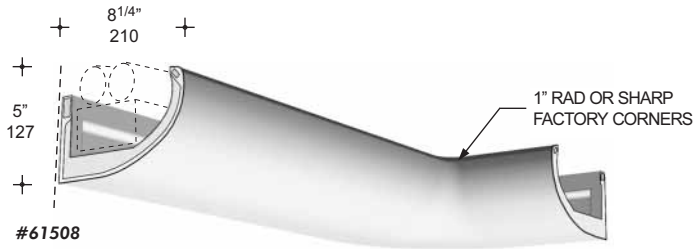

#61508

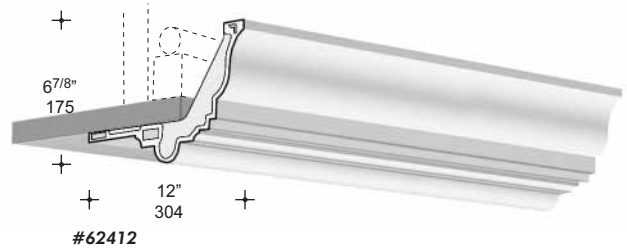

#62412

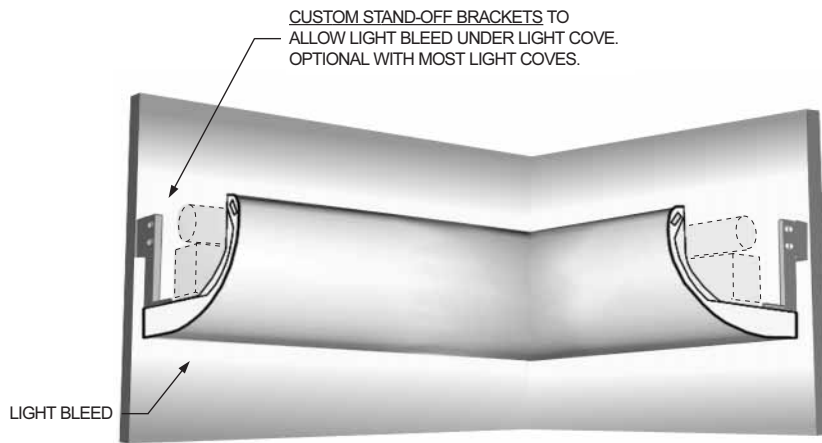

#64307

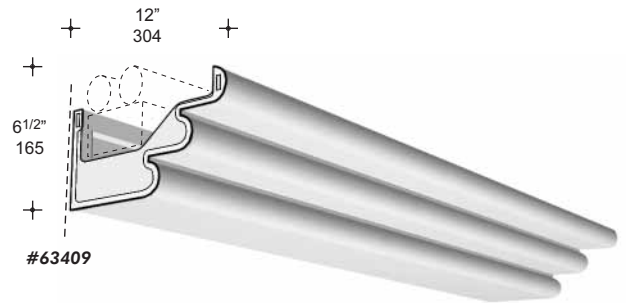

#63409

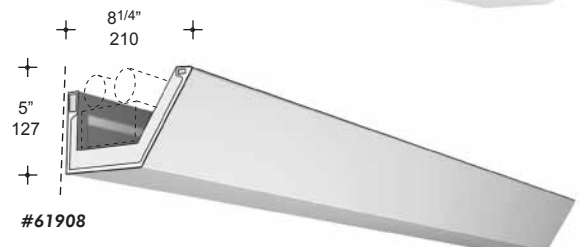

#61908



20 TORO ROAD
NORTH YORK, ONT, M3J 2A7
KUALA LUMPUR, MALAYSIA
TOKYO, JAPAN

TEL (416) 635-8030
FAX (416) 635-6588
TEL (603) 368-1299
TEL (03) 3225-8397

NOTE: LIGHT FIXTURES BY OTHERS

LIGHT COVES

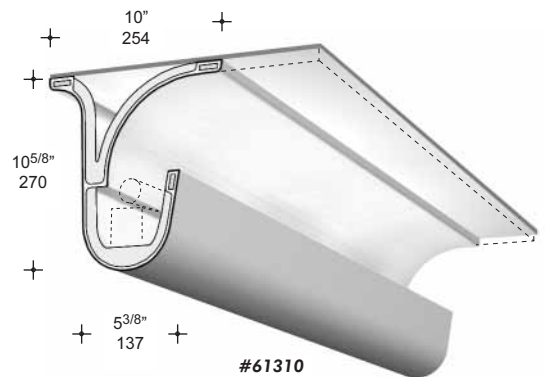
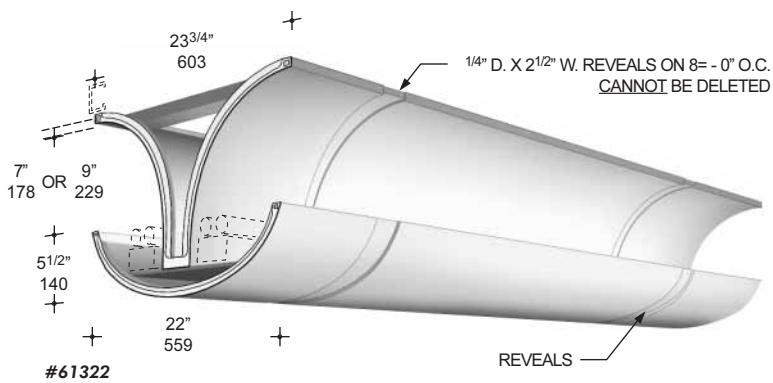
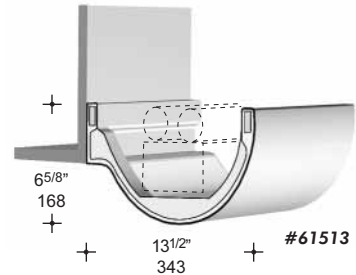
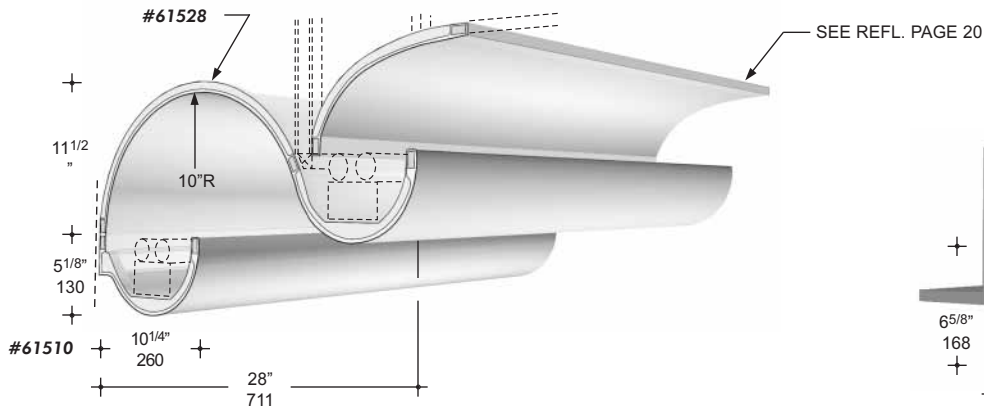
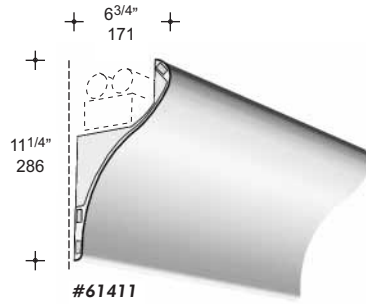
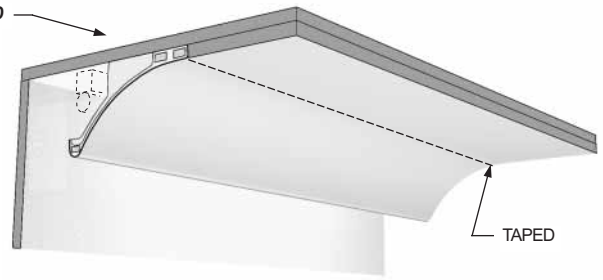
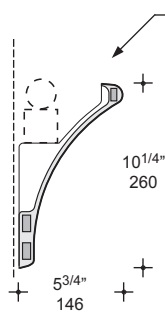
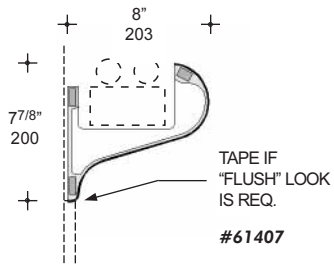

20 TORO ROAD
NORTH YORK, ONT, M3J 2A7
KUALA LUMPUR, MALAYSIA
TOKYO, JAPAN

TEL (416) 635-8030
FAX (416) 635-6588
TEL (603) 368-1299
TEL (03) 3225-8397

NOTE: LIGHT FIXTURES BY OTHERS

LIGHT COVES

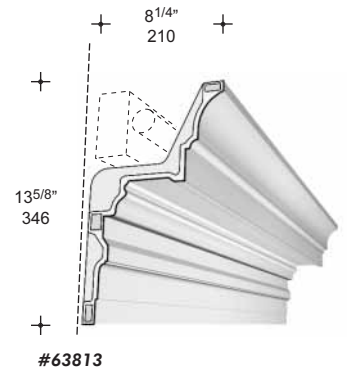
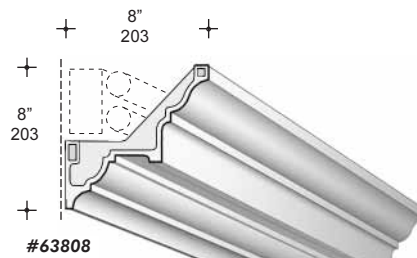
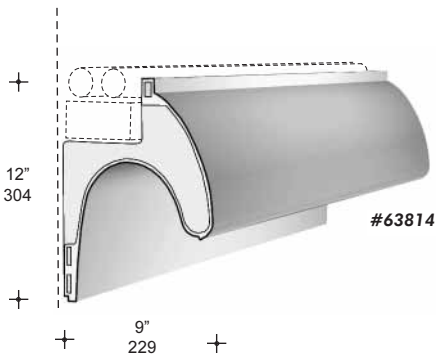
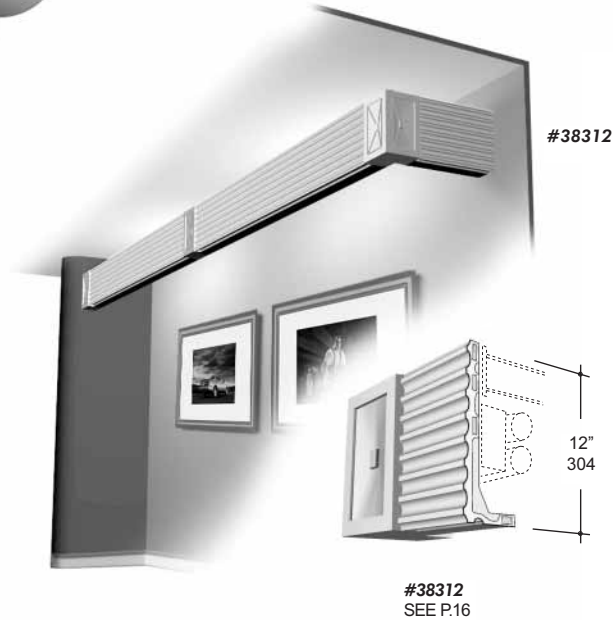
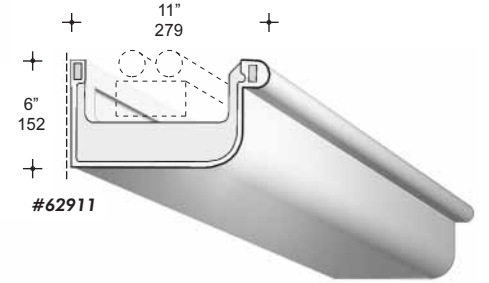
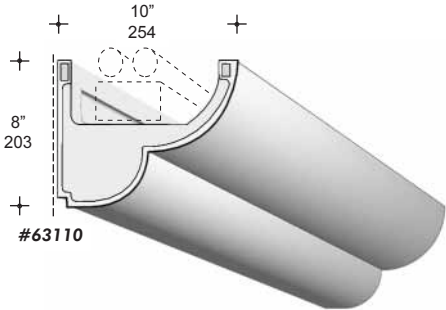
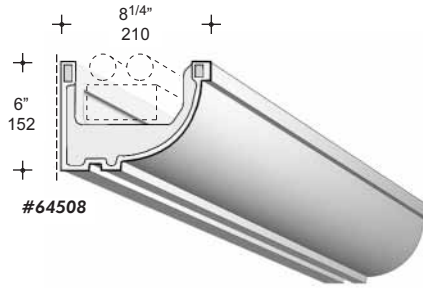
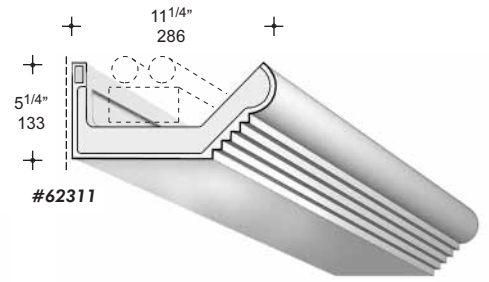
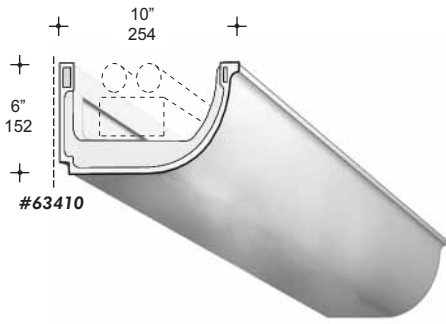

20 TORO ROAD
NORTH YORK, ONT, M3J 2A7
KUALA LUMPUR, MALAYSIA
TOKYO, JAPAN

TEL (416) 635-8030
FAX (416) 635-6588
TEL (603) 368-1299
TEL (03) 3225-8397

NOTE: LIGHT FIXTURES BY OTHERS

LIGHT COVES

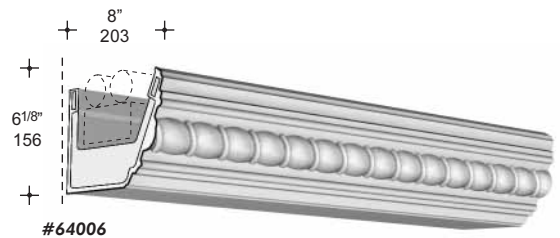
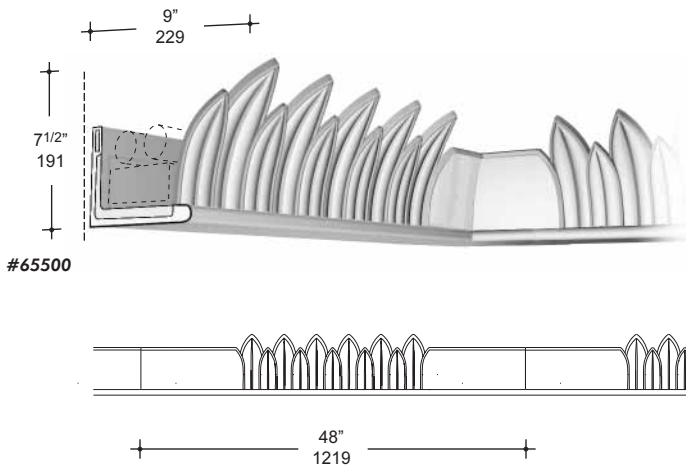
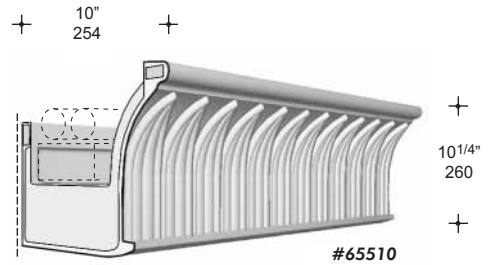
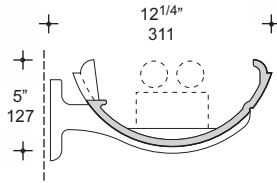
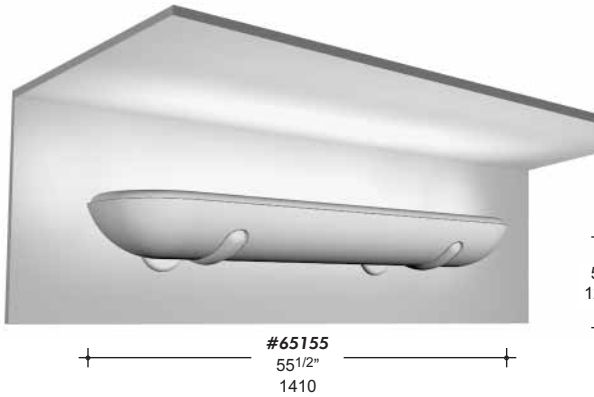
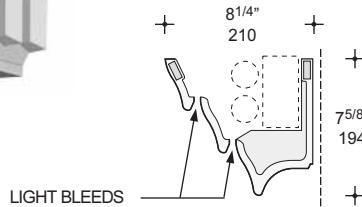
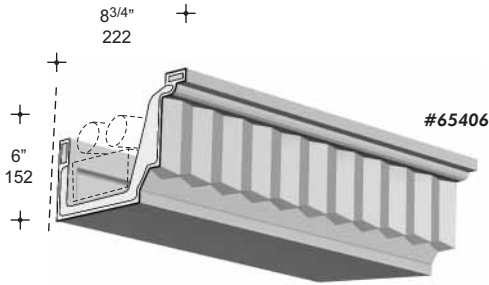
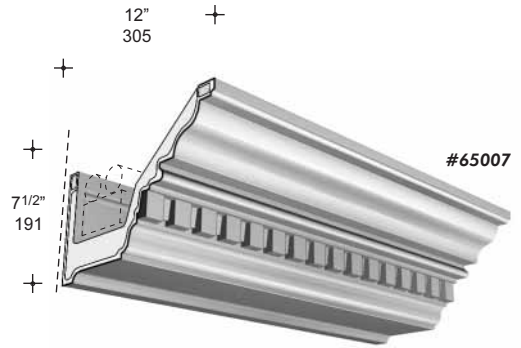
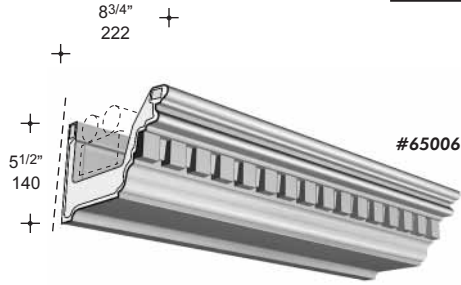

20 TORO ROAD
NORTH YORK, ONT, M3J 2A7
KUALA LUMPUR, MALAYSIA
TOKYO, JAPAN

TEL (416) 635-8030
FAX (416) 635-6588
TEL (603) 368-1299
TEL (03) 3225-8397

NOTE: LIGHT FIXTURES BY OTHERS

LIGHTING ACCESSORIES

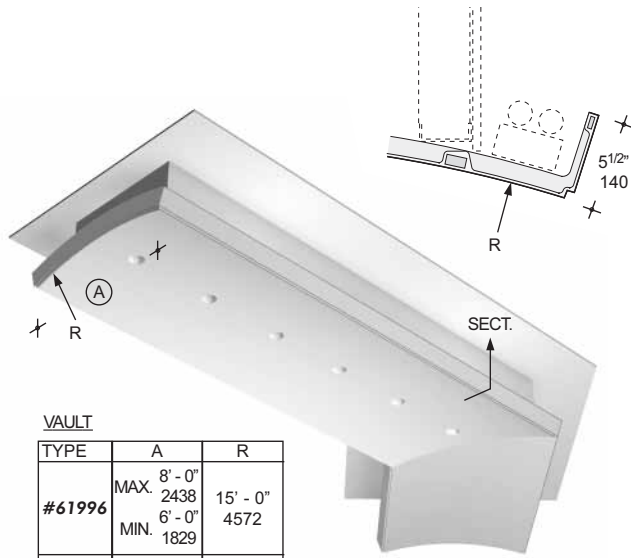

VAULT

TYPE	A	R
#61996	MAX. 8' - 0" 2438	15' - 0" 4572
	MIN. 6' - 0" 1829	
#61960	MAX. 5' - 0" 1524	6' - 6" 1981
	MIN. 3' - 6" 1067	

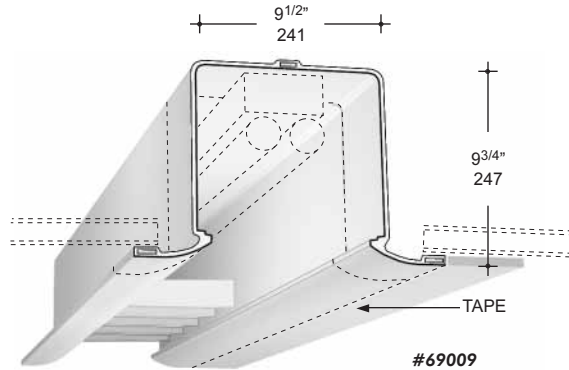

#69009
CONT. LIGHT VALANCE
LENSES BY OTHERS

+ 8" +
203
FLAT
INSIDE
8"
203 +

#69016

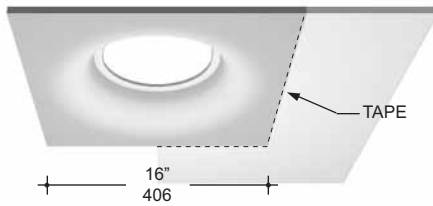

OPENINGS AS REQ.

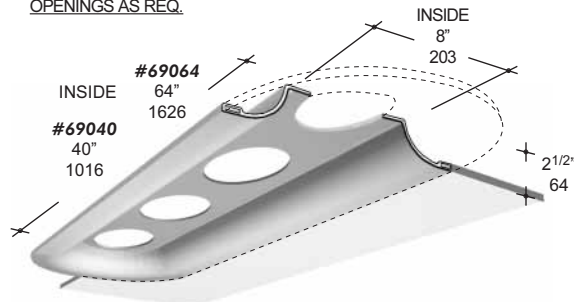

LIGHT COFFERS

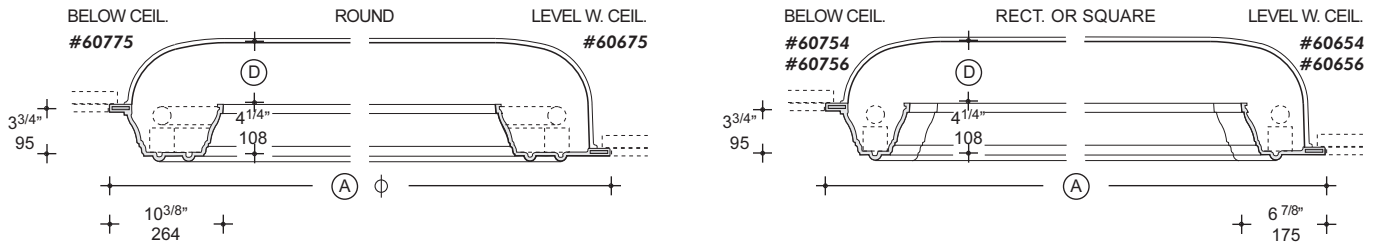

	TYPE	TYPE	(A)	(D)	LIGHT FIX.
RECT.	LEVEL	#60654	54 1/2" X 34 1/2"	MIN.	2 X 2'(600)
	BELOW	#60754	1384 X 876	4 1/2"	2 X 4'(1200)
SQUARE	LEVEL	#60656	56 1/2" X 56 1/2"	114	4 X 4'(1200)
	BELOW	#60756	1435 X 1435	MAX.	
ROUND	LEVEL	#60675	75" ϕ	7"	8 X 2'(600)
	BELOW	#60775	1905 ϕ	178	

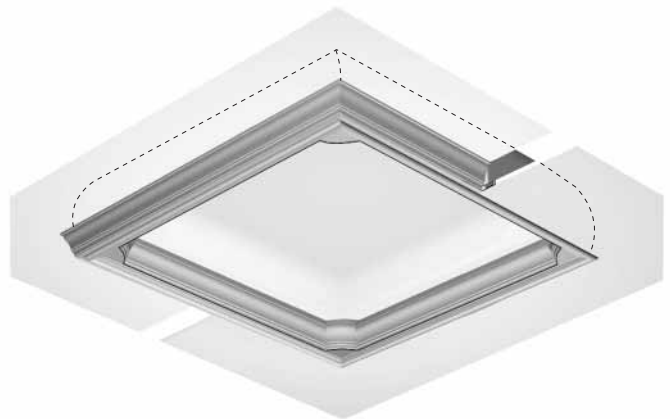

INDIRECT LIGHT COFFERS FOR "T" BAR CEILINGS.
 (FOR 4' & 8' SLIM LINE LIGHT TUBES)
 NOTE: COFFERS CANNOT BE MOUNTED IN CONTINUOUS ROWS!

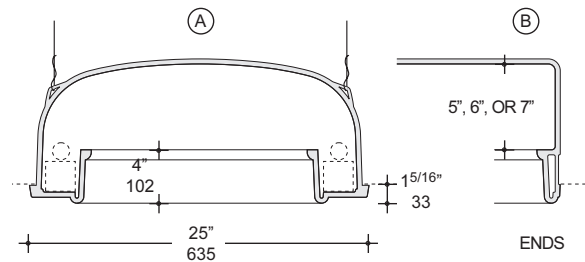
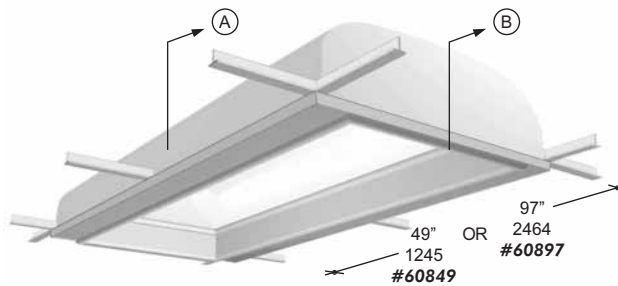

20 TORO ROAD
 NORTH YORK, ONT, M3J 2A7
 KUALA LUMPUR, MALAYSIA
 TOKYO, JAPAN

TEL (416) 635-8030
 FAX (416) 635-6588
 TEL (603) 368-1299
 TEL (03) 3225-8397

DOMES

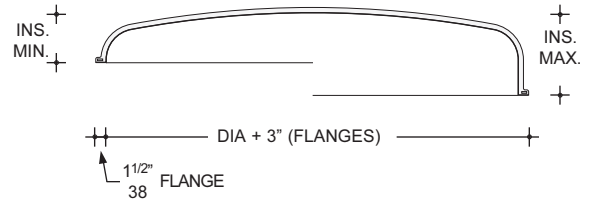
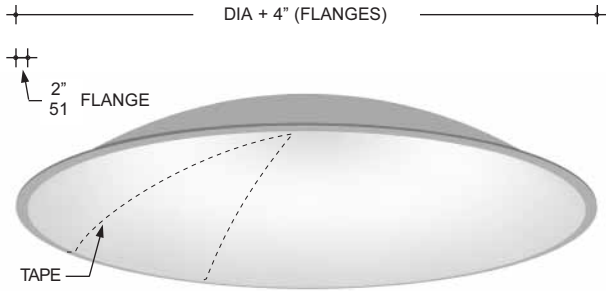

SPHERICAL DOMES [SERIES #70000]

	DIA.	20' 6096	18' 5486	16' 4877	14' 4267	12' 3658	10' 3048	9' 2743	8' 2438	7' 2134	6' 1829	5' 1524	4' 1219
INSIDE	(H)	34 1/2" 876	27 1/2" 699	31 1/2" 800	36 7/8" 937	25 5/8" 651	20 1/2" 521	23 3/8" 594	25 1/2" 648	18" 457	17 1/8" 435	20 7/8" 530	10 7/8" 276
	(H)	24" 610	21 1/4" 489	21 3/8" 543	23 1/2" 597	16 7/8" 429	17 1/8" 435	16 1/4" 413	17 5/8" 448	13 1/8" 333	12 1/2" 318	11" 279	
	(H)			15" 381	16 1/4" 413		11 1/2" 292		12 1/2" 318				

DOMES [SERIES #70100]

	DIA.	7'-6" 2286	6'-0" 1829	5'-0" 1524	4'-0" 1219
INSIDE	MIN.	10" 254	8" 203	7 1/4" 184	6 1/2" 165
	MAX.	18" 457	16" 406	12" 304	12" 304

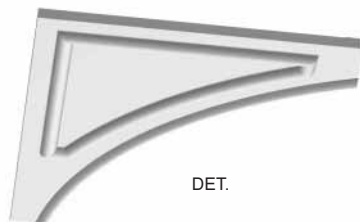
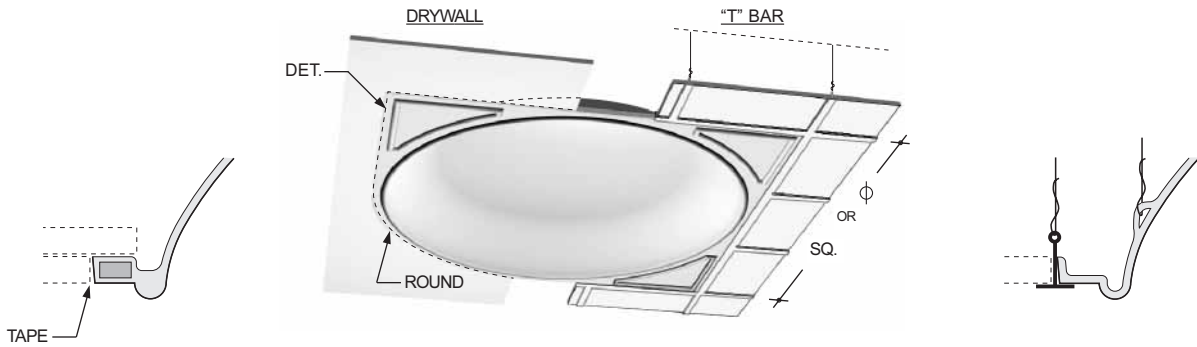

ROUND	#70236	#70248	#70272
φ	35 3/4" 908	47 3/4" 1213	71 3/4" 1822
SQUARE	#70336	#70348	#70372
IMPERIAL	35 3/4"	47 3/4"	71 3/4"
SQUARE	#70436	#70448	#70472
METRIC	895	1195	1795
HEIGHT	7 1/8" 181	8" 203	9 5/8" 244
THE SQUARE DOMES FIT "T" BAR BUT THEY HAVE TO BE INDEPENDENTLY SUSPENDED.			



20 TORO ROAD
NORTH YORK, ONT, M3J 2A7
KUALA LUMPUR, MALAYSIA
TOKYO, JAPAN

TEL (416) 635-8030
FAX (416) 635-6588
TEL (603) 368-1299
TEL (03) 3225-8397

DOMES

COFFER DOMES

TYPE	#71015	#71011	#71008
DIA.	15' - 2" 4623	11' - 0" 3353	8' - 0" 2438
(H) INS.	27 ³ / ₈ " 695	20" 508	15" 381

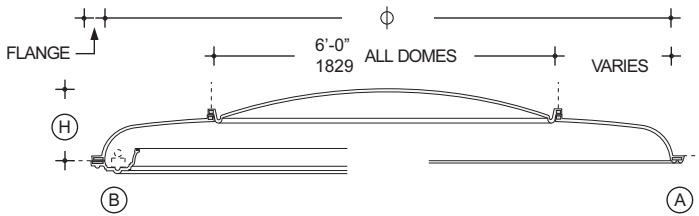
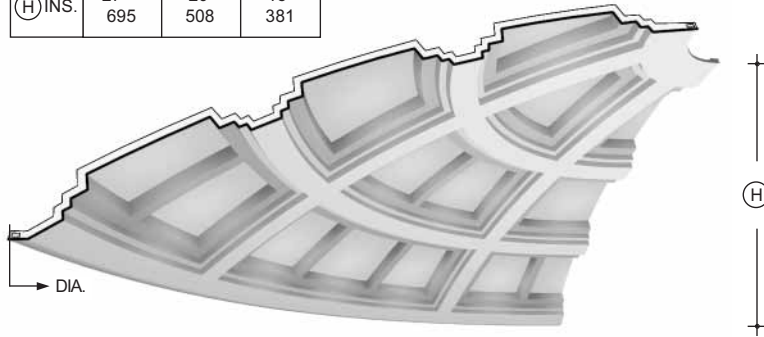

ALL DOMES HAVE 6' - 0" DIA CENTRE

DOMES	#71208	#71210	#71212	#71214	#71216
TOTAL ϕ	8'-0" 2438	10'-0" 3048	12'-0" 3658	14'-0" 4267	16'-0" 4877
(H)	13 ¹ / ₂ " 343	14 ³ / ₄ " 375	16" 406	17 ¹ / ₄ " 438	18 ¹ / ₂ " 470
LIGHTC	#71308	#71310	#71312	#71314	#71316

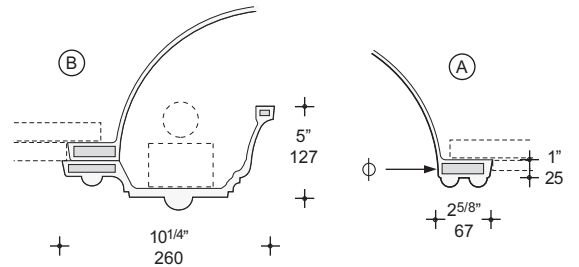

STEPPED DOMES (ROUND OR ELONGATED)

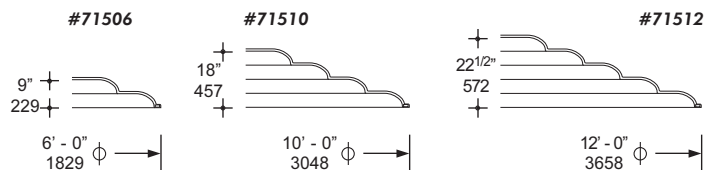
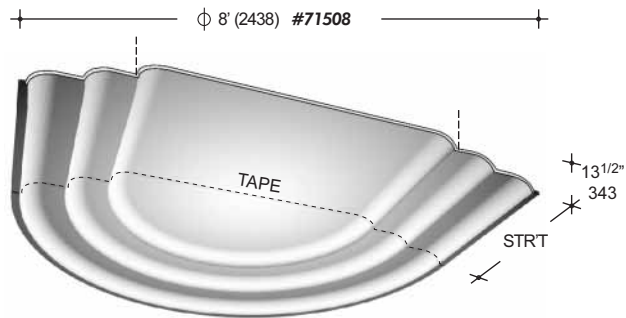

20 TORO ROAD
NORTH YORK, ONT, M3J 2A7
KUALA LUMPUR, MALAYSIA
TOKYO, JAPAN

TEL (416) 635-8030
FAX (416) 635-6588
TEL (603) 368-1299
TEL (03) 3225-8397

DESIGN YOUR OWN CEILING
WITH SPHERICAL PANELS

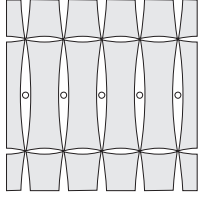
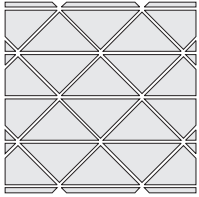

1. THE MAX. SIZE PANEL IS 7'-4" (2235) SQUARE.
2. THE PANEL SURFACE IS SPHERICAL
3. SPHERICAL PANELS WITH A DIFFERENT RADIUS CAN BE MADE ON A CUSTOM BASIS.
4. PROVIDE INSTALLATION ACCESS.

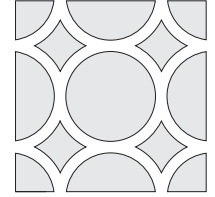
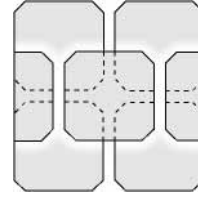

192"(4877) #72192

PANEL R. OR

140"(3556) #72140

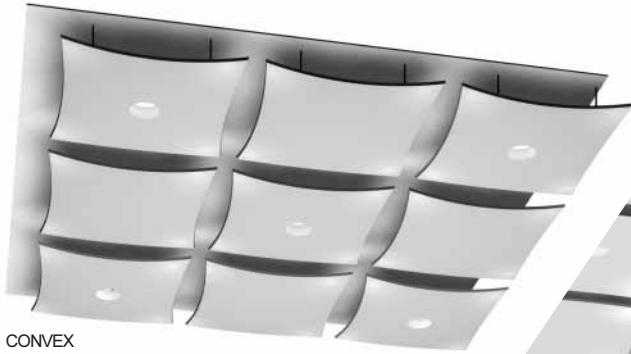

CONVEX

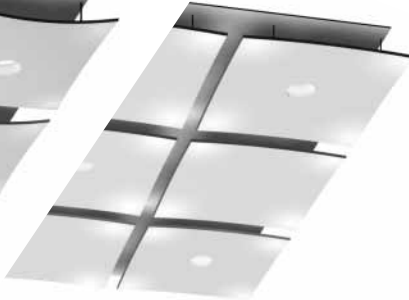

CONCAVE

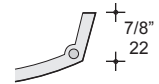

STANDARD EDGE

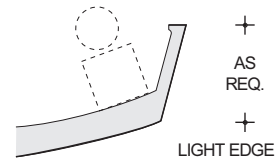

AS REQ.
LIGHT EDGE

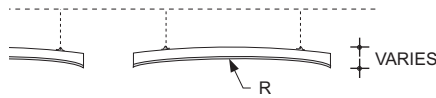
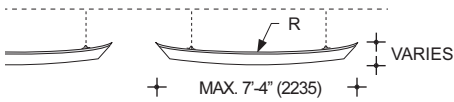

GROIN VAULTS

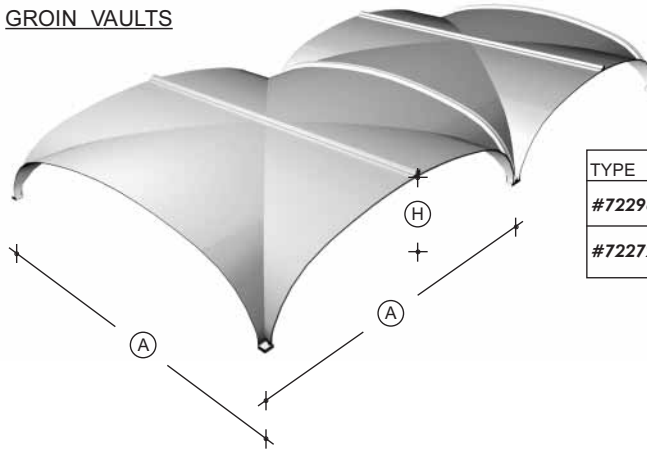

TYPE	A	H
#72296	96" 2438	20" 508
#72272	72" 1829	16" 406

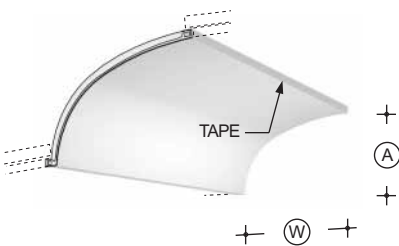

VAULTS & HALF VAULTS
SEND US A SKETCH WITH (H) & WIDTH (W)
TO CHECK IF EXISTING MOLDS CAN BE USED.

TYPE #77000

SEE PAGE 20 FOR STANDARD REFLECTORS

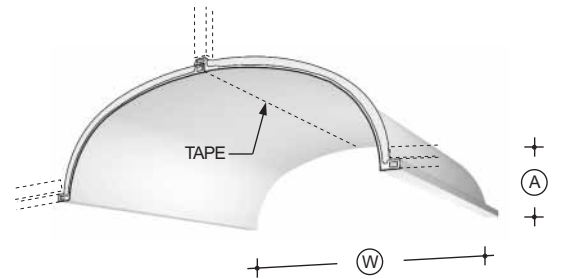

20 TORO ROAD
NORTH YORK, ONT, M3J 2A7
KUALA LUMPUR, MALAYSIA
TOKYO, JAPAN

TEL (416) 635-8030
FAX (416) 635-6588
TEL (603) 368-1299
TEL (03) 3225-8397

COFFERS

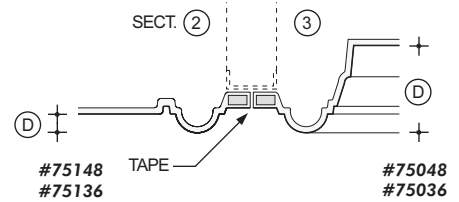
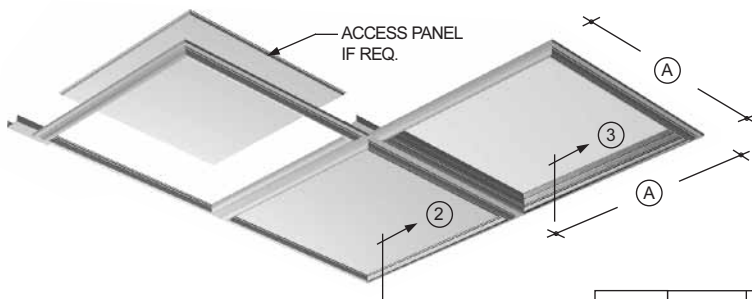
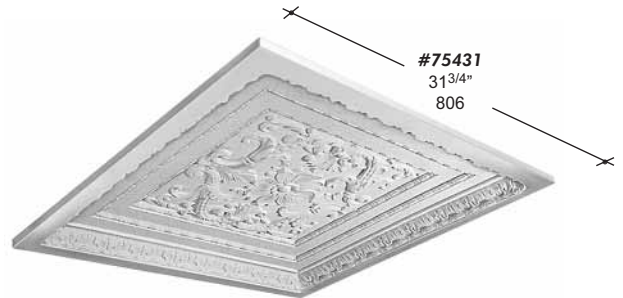
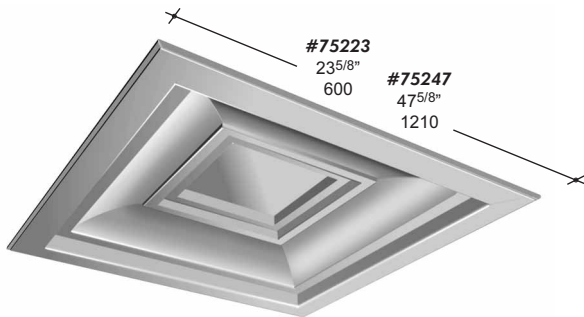
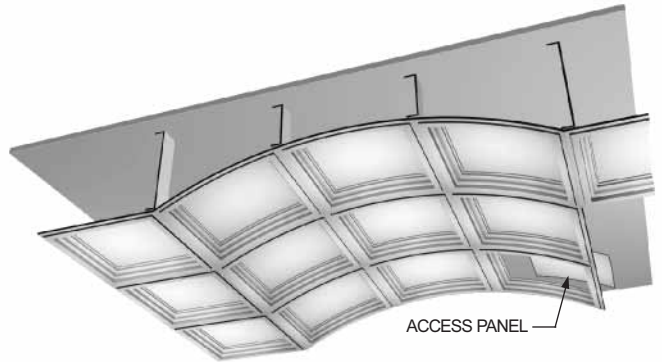
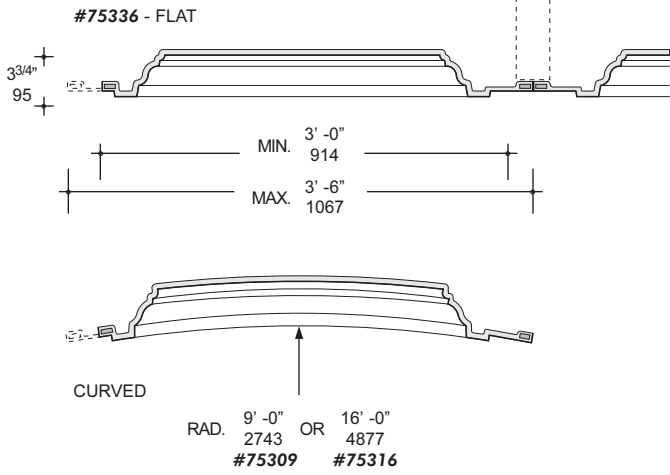

TYPE	#75048	#75148	#75036	#75136
Ⓐ	48" OR 1200	48" OR 1200	36" OR 900	36" OR 900
Ⓓ	3 1/2" 89	3/4" 19	3 3/8" 86	5/8" 16



20 TORO ROAD
NORTH YORK, ONT, M3J 2A7
KUALA LUMPUR, MALAYSIA
TOKYO, JAPAN

TEL (416) 635-8030
FAX (416) 635-6588
TEL (603) 368-1299
TEL (03) 3225-8397

QuarryCast® (mo

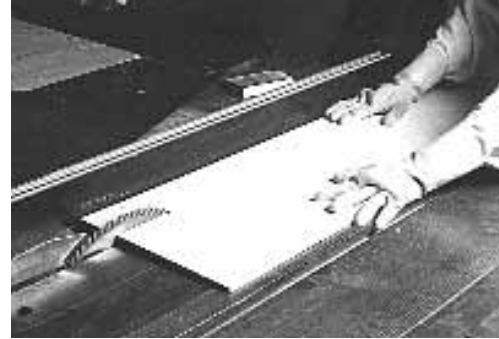

QuarryCast® veneer can be cut on any table saw.

Lightweight - 2 1/2 lbs / sq.ft. (12.5 kg/s.m.)

For signs, see page 51.



Plywood or drywall back-up.

Veneer (5/16" - 8mm thick) adhered.

Corner moulding - screwed on.

Screws are countersunk and filled with grout.

Grouted joints.

Baseboard with 90° return,

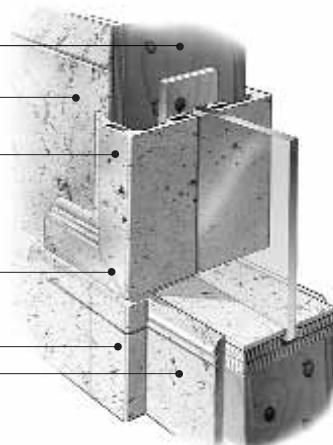

See page 27 for mouldings.

ed stone) - The easy way

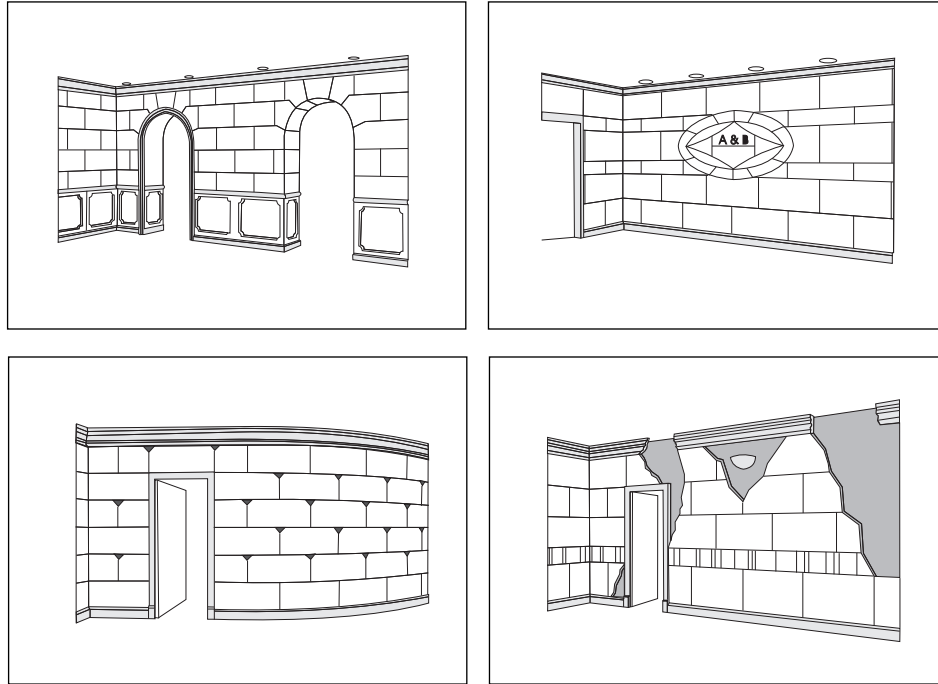

“VENEER” PANEL JOINTS

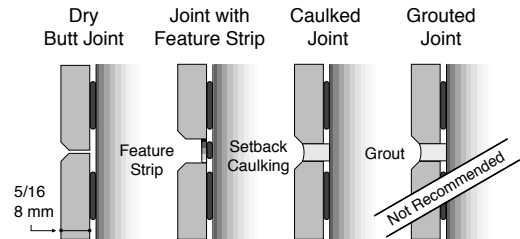

“VENEER” STANDARD MANUFACTURED SIZES

FP=flat panels - 48" (1220) Long

- FP.1248 - H= 12" (305)
- FP.1648 - H= 16" (406)
- FP.1848 - H= 18" (457)
- FP.2448 - H= 24" (610)
- FP.3948 - H= 39" (1000)

C = Corners 90° (outside)

* = Max 6" (152) legs

RP.= radius panel-custom RAD. face or back

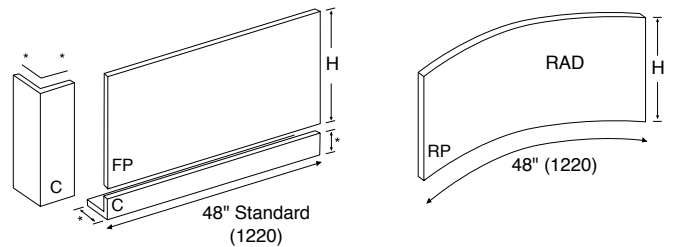

BORDERS & TILES

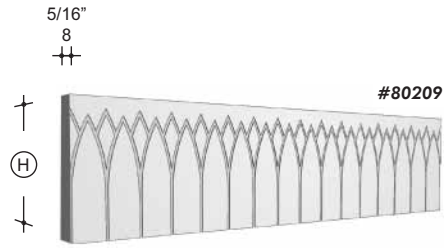

$$\textcircled{H} = \begin{matrix} \text{MAX.} & - & \text{MIN.} \\ 9'' & - & 4'' \\ 229 & & 102 \end{matrix}$$

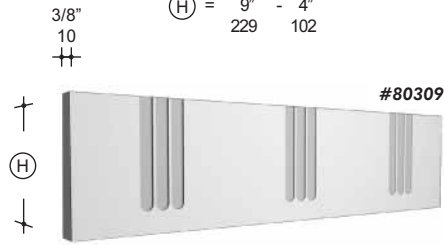

$$\textcircled{B} = \begin{matrix} \text{MAX.} & - & \text{MIN.} \\ 23 \frac{15}{16}'' & - & 8'' \\ 608 & & 203 \end{matrix}$$

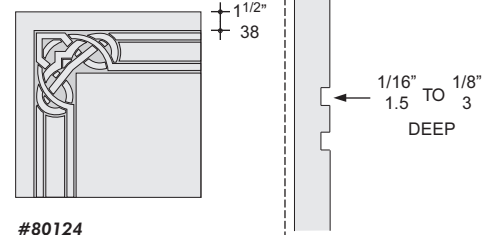
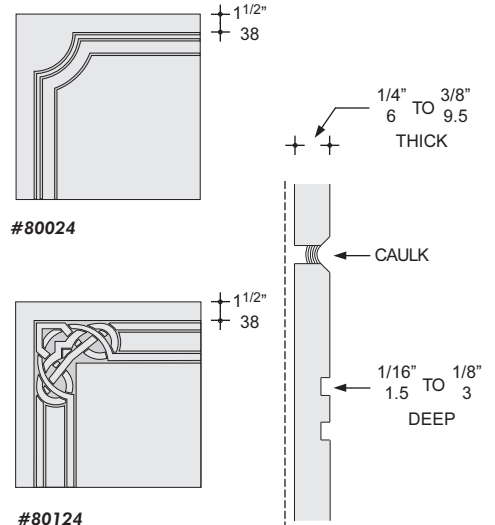
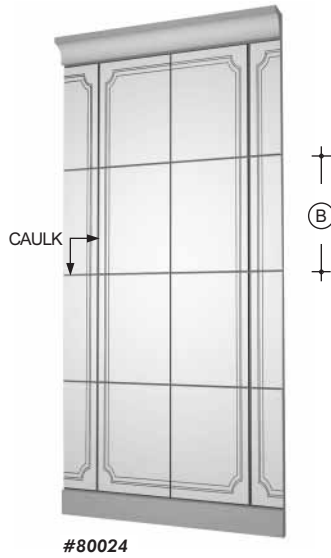
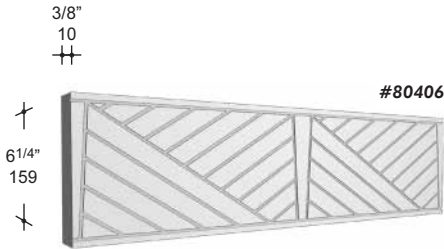

COINS

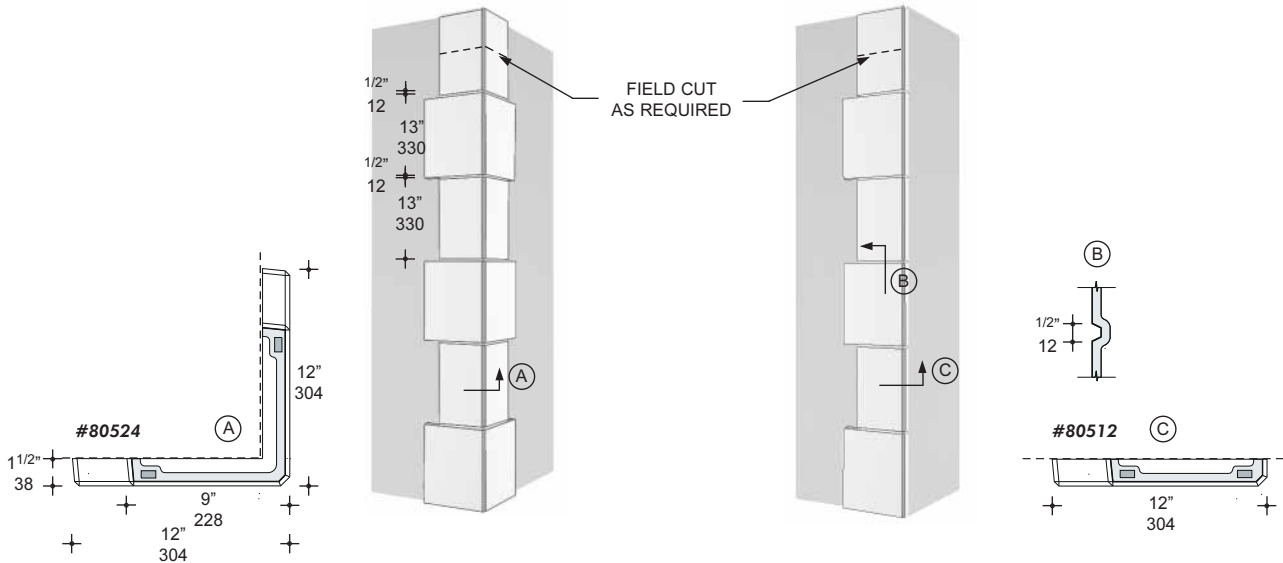

20 TORO ROAD
NORTH YORK, ONT, M3J 2A7
KUALA LUMPUR, MALAYSIA
TOKYO, JAPAN

TEL (416) 635-8030
FAX (416) 635-6588
TEL (603) 368-1299
TEL (03) 3225-8397

QUARRYCAST® CUSTOM SIGNS [INTERIOR ONLY]

NOTE: SINGLE SIGNS ARE EXPENSIVE DUE TO MOLD COSTS.
#88600

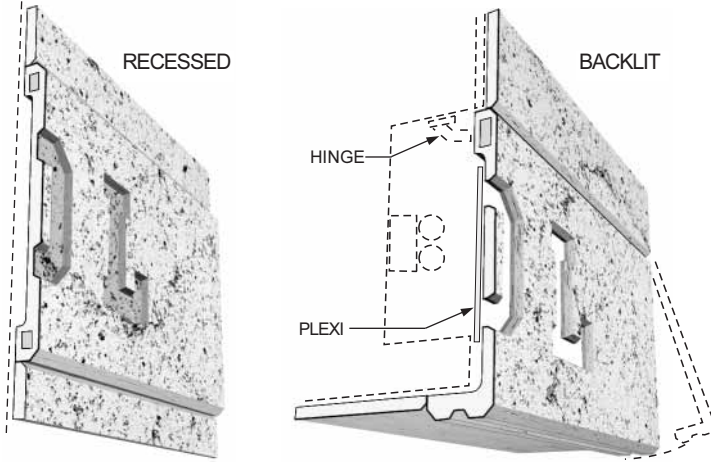

CLOSED LOUVRE PANEL
ONE SIDED ONLY [1" THICK] VARIABLE LENGTHS.
#88772

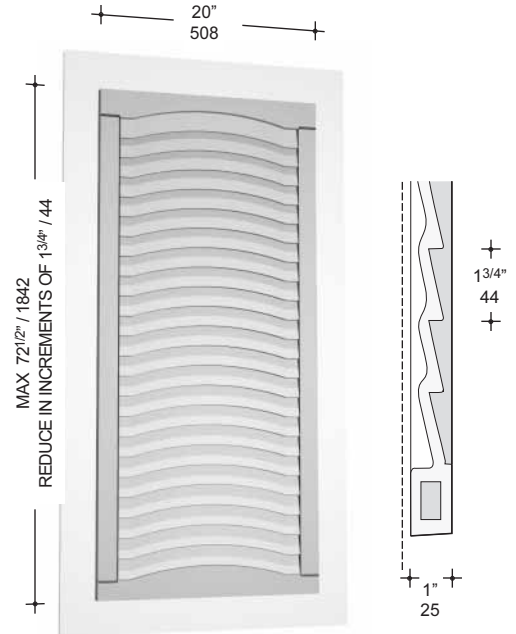

WAINSCOT
#88948

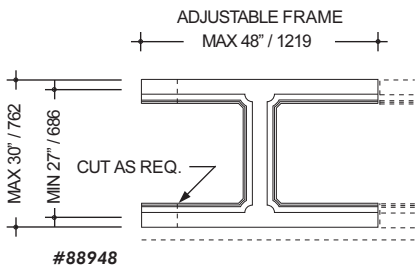
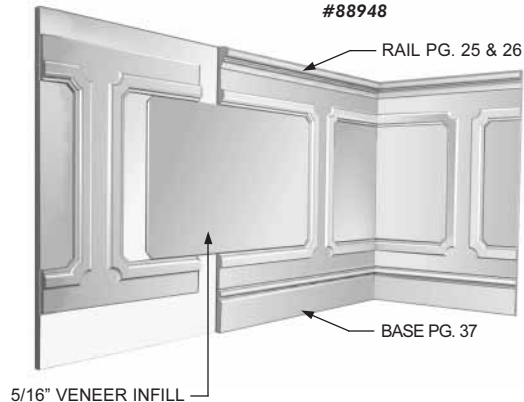

WALL PANEL

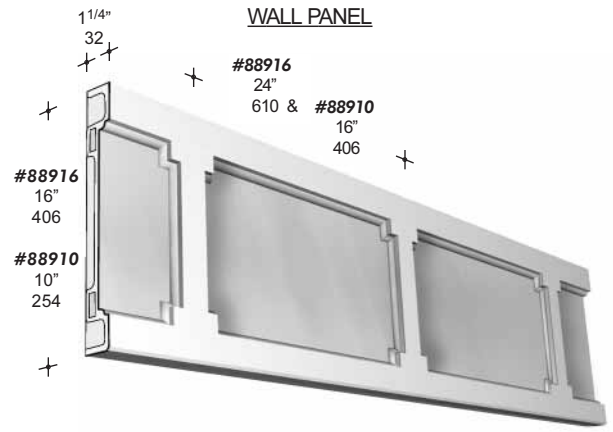

20 TORO ROAD
NORTH YORK, ONT, M3J 2A7
KUALA LUMPUR, MALAYSIA
TOKYO, JAPAN

TEL (416) 635-8030
FAX (416) 635-6588
TEL (603) 368-1299
TEL (03) 3225-8397

BALLUSTER RAILINGS

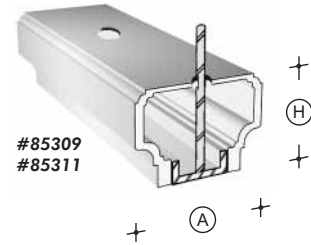
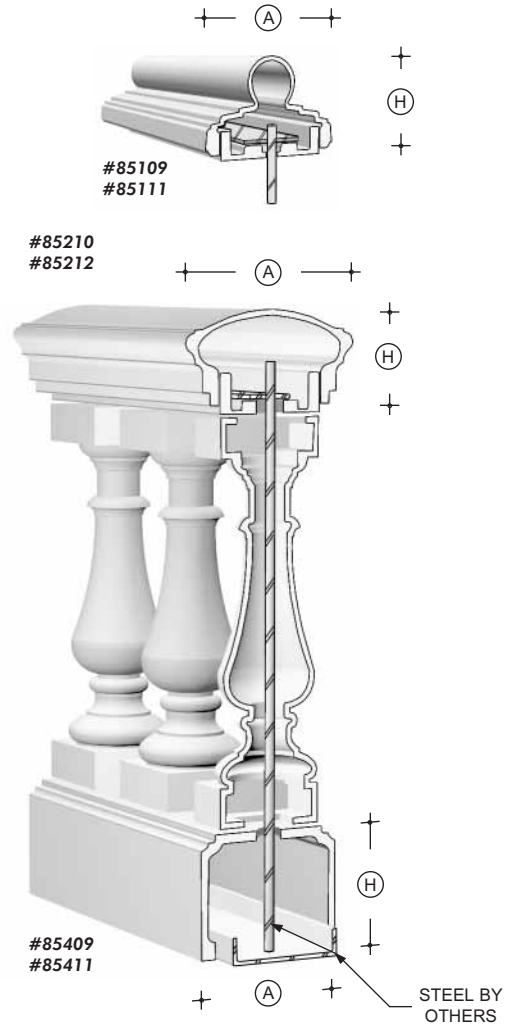
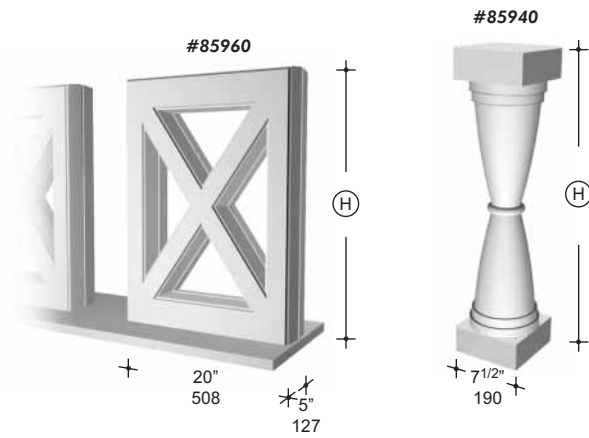
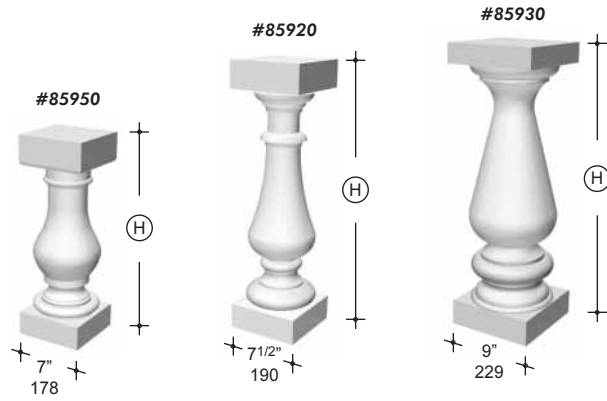

BALLUSTERS & POSTS

TYPE	MIN. (H)	MAX (H)
#85920	25"/635	33"/838
#85930	25"/635	31"/787
#85940	26"/660	32"/813
#85950	17 1/2"/445	21"/533
#85960	26"/660	32"/813
#85800	38"/965	49"/1245

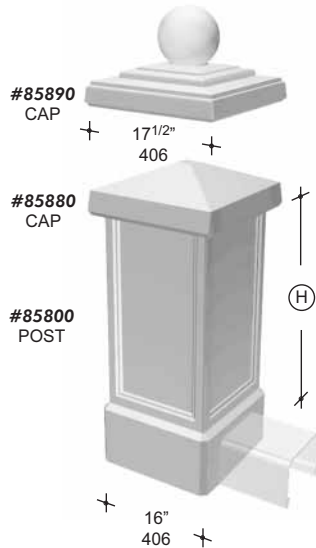

RAILINGS

TYPE	(A)	(H)
#85109	9 1/2"/235	6 3/8"/162
#85111	11 1/2"/292	6 1/2"/165
#85210	10 1/4"/235	4 5/8"/117
#85212	12 3/4"/324	5 3/4"/146

BASES

TYPE	(A)	MIN. (H)	MAX (H)
#85409	9"/229	4"/140	10"/254
#85411	11 1/4"/286	4"/140	10"/254
#85309	9"/229	5 1/2"/102	10"/254
#85311	11 1/4"/286	5 1/2"/102	10"/254



20 TORO ROAD
NORTH YORK, ONT, M3J 2A7
KUALA LUMPUR, MALAYSIA
TOKYO, JAPAN

TEL (416) 635-8030
FAX (416) 635-6588
TEL (603) 368-1299
TEL (03) 3225-8397

SCREENS
ONE OR TWO SIDED - OPEN OR CLOSED

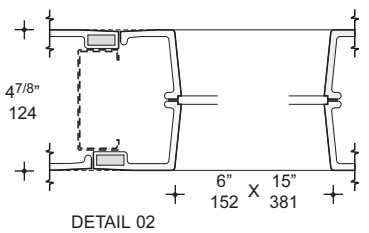
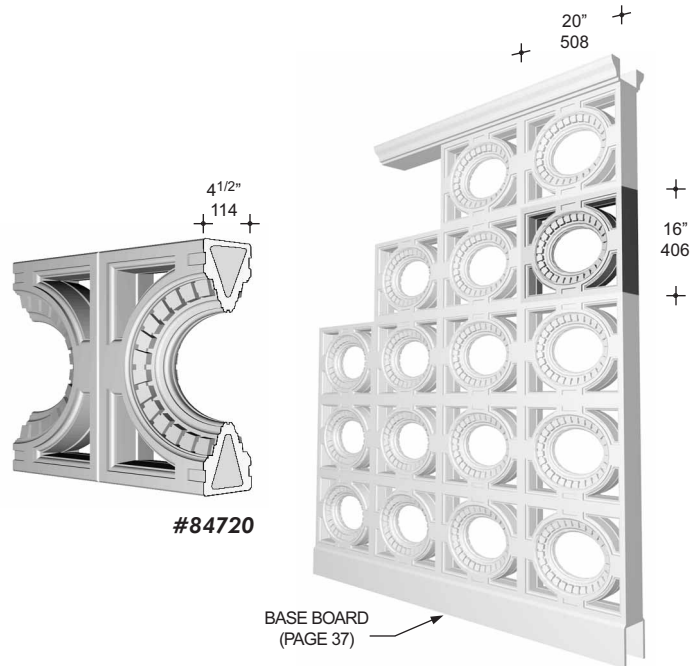
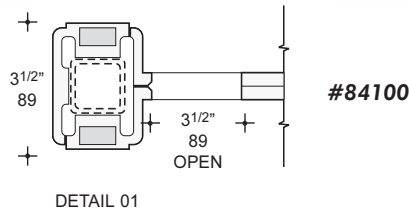
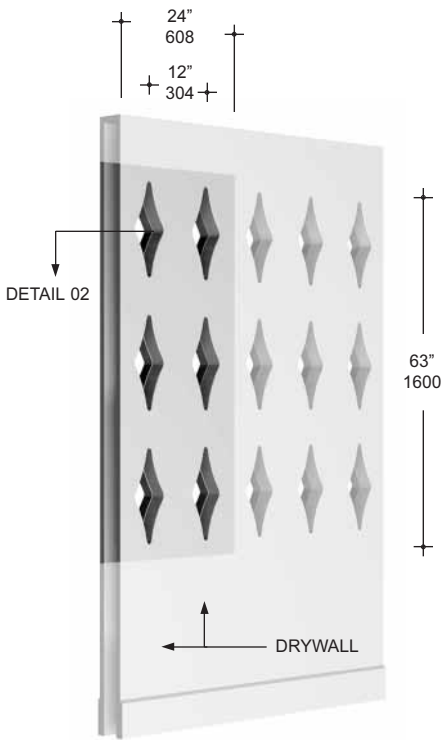
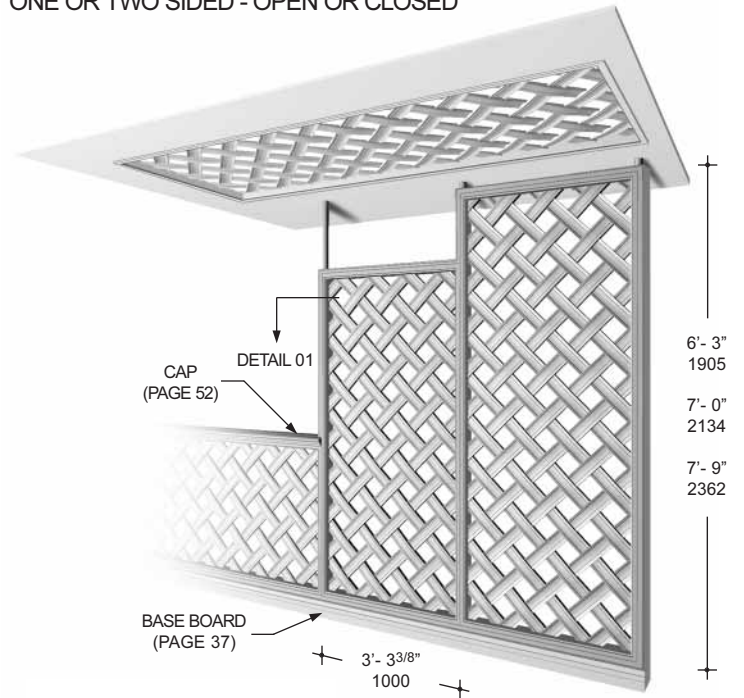
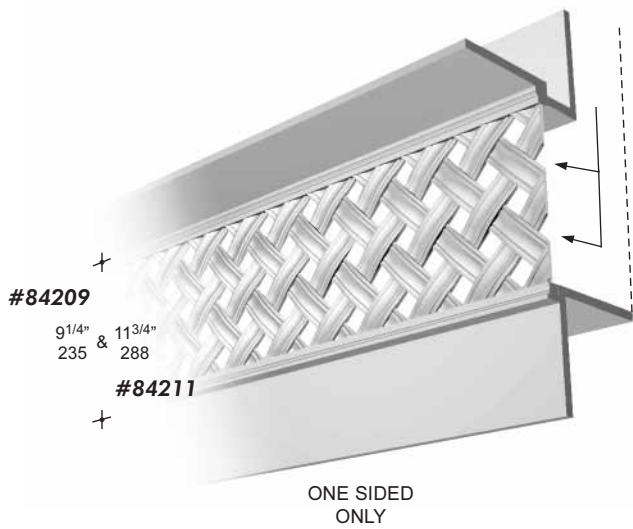

20 TORO ROAD
NORTH YORK, ONT, M3J 2A7
KUALA LUMPUR, MALAYSIA
TOKYO, JAPAN

TEL (416) 635-8030
FAX (416) 635-6588
TEL (603) 368-1299
TEL (03) 3225-8397

"FABRIC" PANELS

THESE GYPSUM BASED PANELS ARE NON-FLAMMABLE.

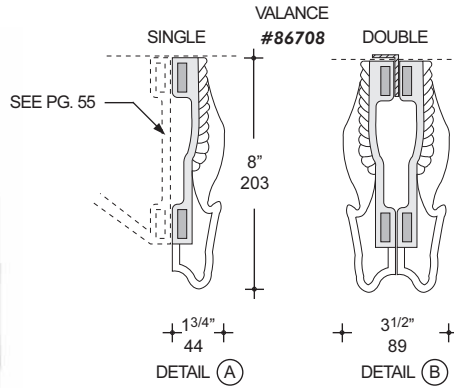
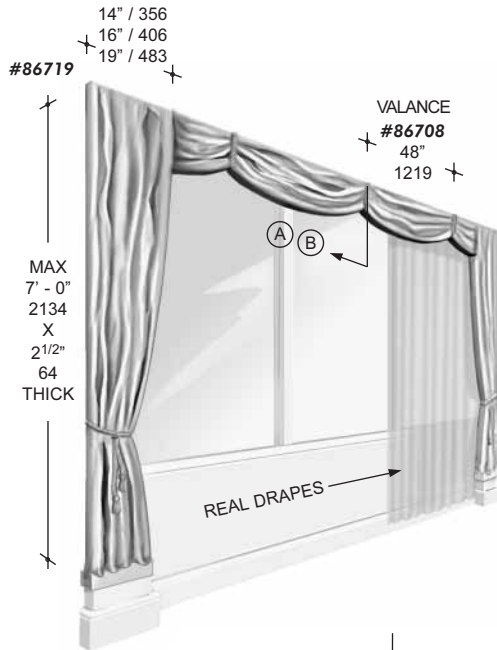

COLUMNS		
+	13"	+ #86713
+	18"	+ #86718

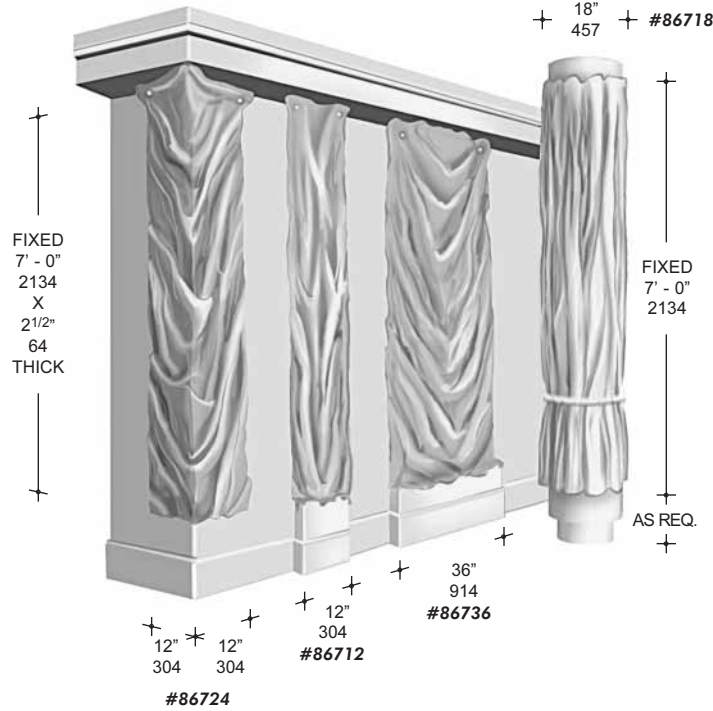
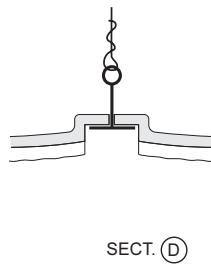
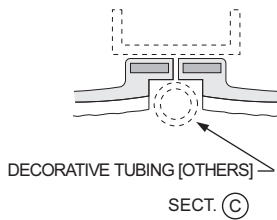
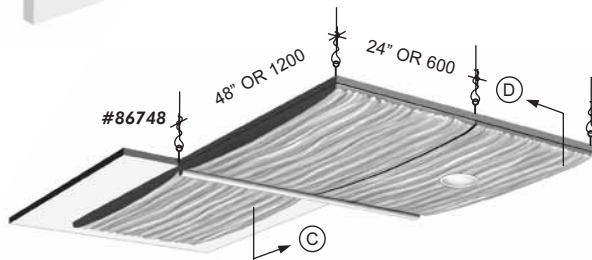

20 TORO ROAD
 NORTH YORK, ONT, M3J 2A7
 KUALA LUMPUR, MALAYSIA
 TOKYO, JAPAN

TEL (416) 635-8030
 FAX (416) 635-6588
 TEL (603) 368-1299
 TEL (03) 3225-8397

BLIND / DRAPERY POCKETS

CONDITIONS VARY AND EACH PROJECT REQUIRES NEW MOLDS
#86000

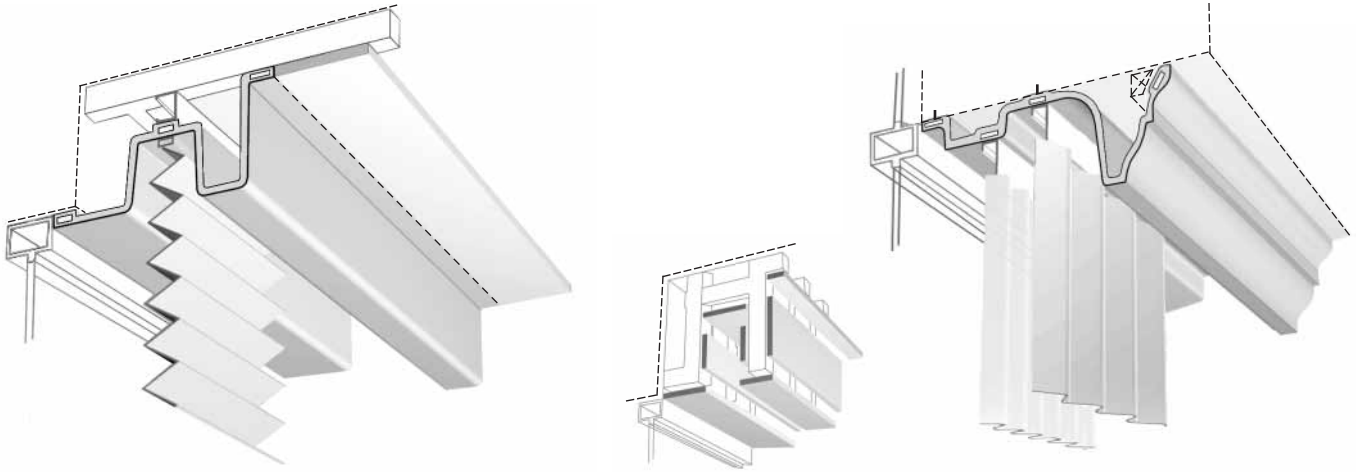

CONVENTIONAL METHOD
MANY DRYWALL STRIPS AND
DIFFICULT TO REACH "JOINT TAPING"

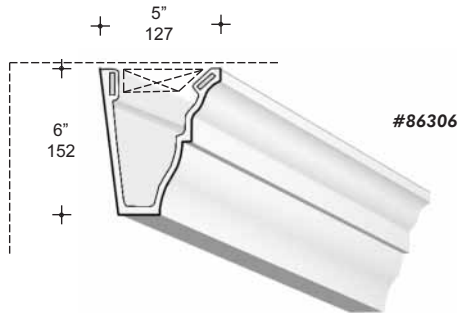

SEE #44706 - PAGE

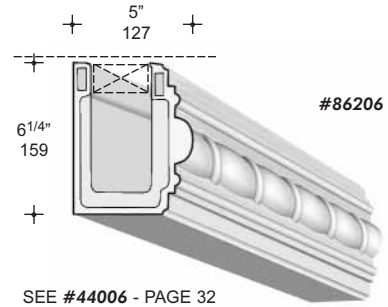

SEE #44006 - PAGE 32

ACOUSTIC TILE TRANSITIONS

#86124

SPECIFY HEIGHT & DEPTH

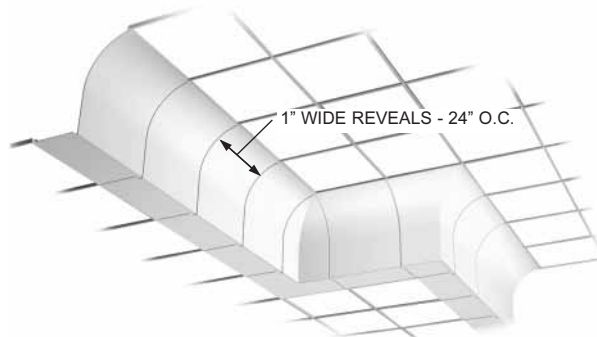
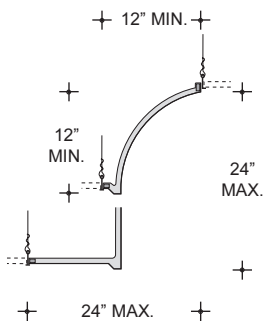

20 TORO ROAD
NORTH YORK, ONT, M3J 2A7
KUALA LUMPUR, MALAYSIA
TOKYO, JAPAN

TEL (416) 635-8030
FAX (416) 635-6588
TEL (603) 368-1299
TEL (03) 3225-8397

PERFORATED PANELS

MOLDS DO NOT EXIST! THESE DESIGNS ARE TO ILLUSTRATE THE POSSIBILITIES.
#87000



ROUND

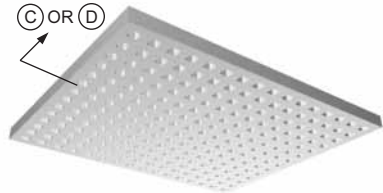
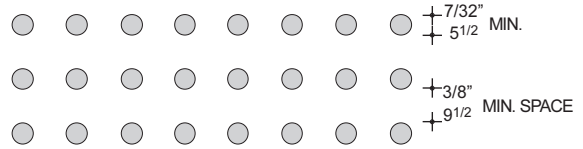

ELONGATED

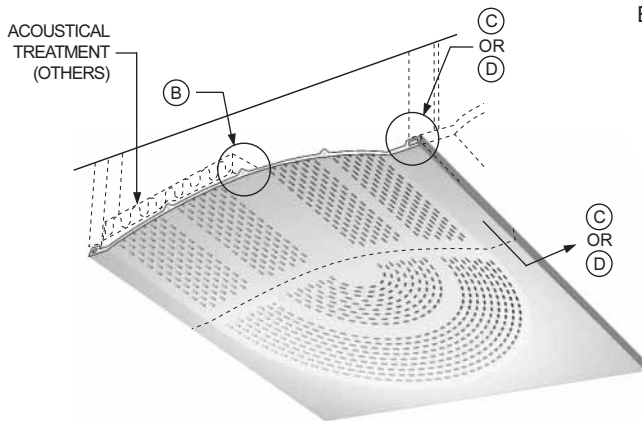
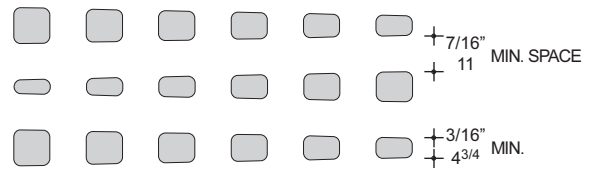

ELONGATED

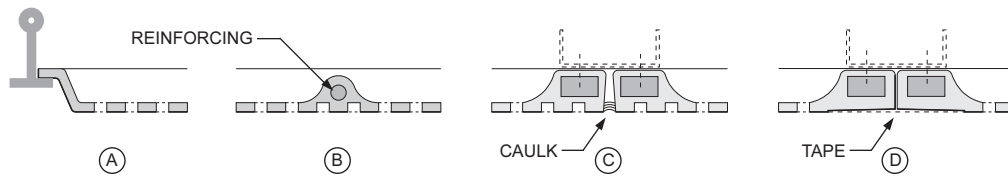
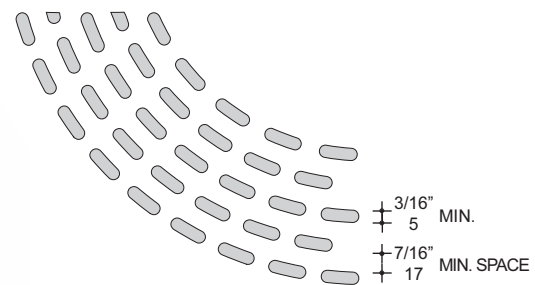

1. ACOUSTICAL TREATMENT MAY BE REQUIRED ON TOP.
2. FOR MAX. OPEN AREA USE ELONGATED HOLES.
3. LARGER PANELS REQUIRE BUILT-IN REINFORCING (B) REDUCING THE OPEN AREA.
4. SMALLER PERFORATIONS OR SPACINGS [THAN SHOWN] ARE NOT POSSIBLE!



20 TORO ROAD
NORTH YORK, ONT, M3J 2A7
KUALA LUMPUR, MALAYSIA
TOKYO, JAPAN

TEL (416) 635-8030
FAX (416) 635-6588
TEL (603) 368-1299
TEL (03) 3225-8397

UMBRELLAS

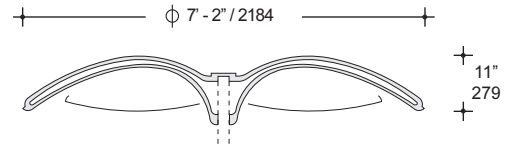
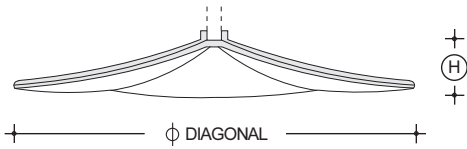

TYPE	#88106	#88107	#88108
φ	6' - 0" 1829	7' - 0" 2133	8' - 0" 2438
H	11 ³ / ₄ " 298	12 ¹ / ₂ " 318	13 ¹ / ₄ " 337

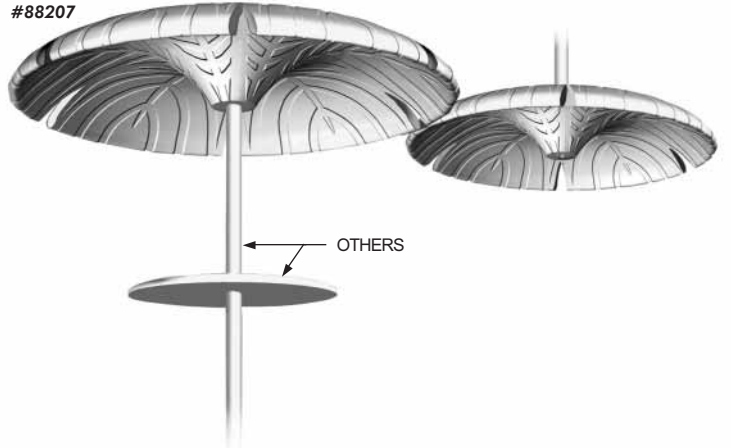
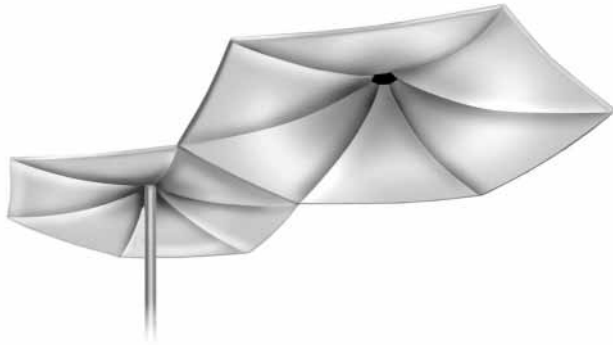

STEPPED PANELS

THESE PANELS CAN BE MADE INTO ANY SHAPE FROM 22³/₄" (578) TO 66" (1676) MAX. SQUARE.

MAX. 66"
1676
MIN. 22³/₄"
578

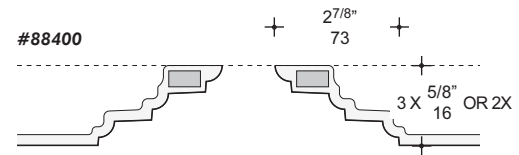
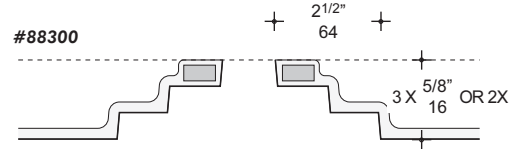
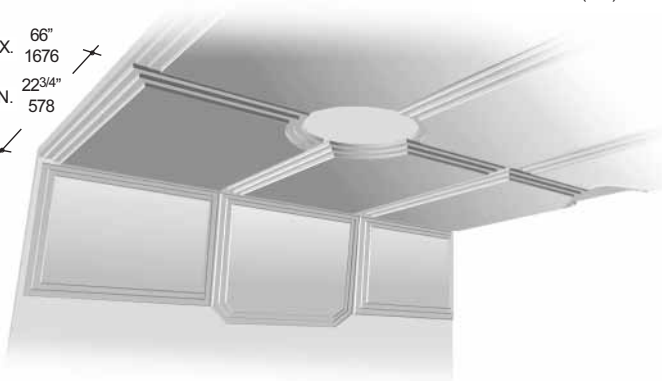

PLANTER / LIGHT BOWLS

AS OTHER

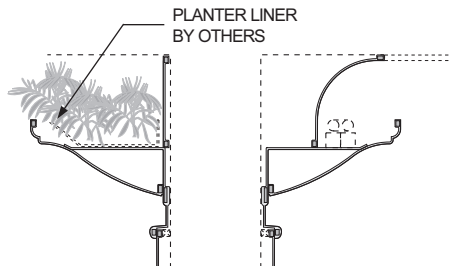

#88548 48" 1219
#88566 66" 1676



FOR COL. φ AND OTHER DIMENSIONS CONTACT FORMGLAS INC.



20 TORO ROAD
NORTH YORK, ONT, M3J 2A7
KUALA LUMPUR, MALAYSIA
TOKYO, JAPAN

TEL (416) 635-8030
FAX (416) 635-6588
TEL (603) 368-1299
TEL (03) 3225-8397

COLUMNS

PAGE	<u>PILASTERS & SQ. COLUMNS</u>
10008-10048 4	30130 17
10514 5	30309 17
10910 5	32506-32509 17
11010 5	32607-32610 17
11137 5	32703-32704 17
11212-11218 5	38300-38319 16 / 40
18006-18024 8	
18106-18141 8	
18206-18228 8	<u>MOULDINGS, CORNICES, ETC.</u>
18420-18441 6	40108-40122 21 / 31
18520-18541 6	40418 21
18614-18622 7	40503 25
18710-18717 7	40712-40723 21
18808-18816 7	40814 21
18908-18912 7	40916 21
	41016 21
	41411 22

CAPITALS & BASES

20142-20143 12	41812 21
20234-20242 12	41912 22
20421-20429 12	42012 22
20514-20527 12	42108-42112 22 / 24
20718-20727 12	42206-42270 18 / 22
20812-20826 13	42405-42408 17 / 19
21309-21324 13	42612 22
21515-21524 12	42806 24
21616 12	43110 23
21812 12	43209 23
21920 12	43308-43310 23
22016-22020 13	43409 23
22112-22118 13	43507 24
22208 13	43608 23
22312-22316 13	43709 23
23009-23024 13 / 14	43810 10 / 23
23112-23124 14	43908 24
23212-23224 14	44003-44008 19 / 24 / 32
23312-23324 14	44104-44109 32
23412-23424 11	44203-44209 23 / 32
23510-23518 11	44304-44307 32
23612-23620 10	44402-44404 32
23710-23716 10	44501-44510 31 / 32
23812-23820 10	44607-44613 24 / 31
24807-24810 10	44701-44707 24 / 31
27006-27028 9	44806-44810 16 / 17 / 18
27106-27128 9	44806-44810 22 / 24
27206-27241 9	44902-44912 16 / 22/ 26
27306-27341 9	45000-45012 25 / 30
27406-27428 9	45101-45105 19 / 25 / 26
27506-27536 9	45205-45209 30
27706-27716 11	45304-45370 19 / 25/ 30
27806-27816 11	45405-45410 25 / 28

MOULDINGS, CORNICES, ETC.

45500-45510 26 / 28
45603-45613 26 / 28
45704-45716 25 / 28
45804-45814 25 / 28 / 29
45903-45907 25
46001-46032 23 / 25/ 26
46102-46194 26 / 27
46200-46207 27
46303-46304 27
46403-46404 27
46503-46529 26 / 29
46600-46677 25 / 28
46701-46704 26
46803-46824 29
48304 19

BASEBOARDS

50106-50112 37
50204-50209 37
50304-50307 37
50406-50412 16 / 37
50606-50612 16 / 37
50704-50710 37

LIGHTCOVES, ETC.

60654-60675 43
60754-60775 43
60849-60897 43
61310-61322 39
61407-61411 25 / 39
61508-61513 38 / 39
61908-61996 38 / 42
62008 38
62113 38
62311 40
62412 38
62911 40
63110 40
63409-63410 38 / 40
63808-63814 10 / 40
64006 41
64307 38
64508 40
65006-65007 41
65155 41
65200-65254 41
65406 41
65500-65510 41
66605 25
69009-69064 42

DOMES, VAULTS, REFLECTORS

70004-70020 44
70104-70107 44
70236-70272 44
70336-70372 44
70436-70472 44
71008-71015 45
71208-71216 45
71308-71316 45
71506-71512 45
72000 46
72140-72192 46
72272-72296 46
75036-75048 47
75136-75148 47
75223-75247 47
75309-75336 47
75431 47
77004-77048 20

BORDERS & TILES

80024-80524 50

BRACKETS

81610-81834 35

PEDIMENTS, BEAMS

83100-83202 34

SCREENS

84100-84720 53

RAILINGS, BALUSTERS, ETC.

85106-85890 24 / 52

"FABRIC" PANELS &

DRAPERY POCKETS

86000-86748 54 / 55

PERFORATED

PANELS

87000 56

MISCELLANEOUS

88106-88948 51 / 57



GOVERNMENT OF SINGAPORE

Your Ref: 137/217/86
Our Ref: 429, J2/12/18
Date: 17 Nov 86

SINGAPORE FIRE SERVICE B,
254 EASTERS ROAD
SINGAPORE 0923

20 NOV 1986

14 Oul Lane, Jurong
Singapore 2662

Dear Sir

'QUARRY CAST' GLASSFIBRE REINFORCED
PIGMENTED CERAMIC CEMENT

Please refer to your application for our acceptance of non-combustible 'Quarry Cast' glassfibre reinforced pigmented ceramic cement.

2 Your application has been duly considered on the basis of SISIR test report of reference G 132941/A/SCA dated 6 Nov 86 to BS 476 to Part 4:1970 (Non-Combustibility Test). We note that the product has passed the above test and can be used as non-combustible building material.

We have no objection to the use of the abovementioned 'Quarry Cast' to the following conditions:

INWARD/OUTWARD	COPY	FILE
BFSPL	3	16
BPHKL		

United States Testing Company, Inc.
California Division
5555 TELEGRAPH ROAD • LOS ANGELES, CALIFORNIA 90040 • (213) 723-7161
Laboratories in Principal Cities

REPORT OF TEST

FORMGLAS, INC.
1015 Timothy Drive
San Jose, CA 95133

FLAME SPREAD CLASSIFICATION AND
SMOKE DENSITY DEVELOPED

GRC INTERIOR MATERIAL/QUARRRYCAST
WITH PLYWOOD REINFORCEMENT

October 31, 1990

TEST REPT
SIGNED FOR

By: *Michael Todd*
C. Michael Todd
Senior Test Technician

Page 1 of 5

THIS REPORT APPLIES ONLY TO THE EDWARDS OR PROCEDES CERTIFIED AND TO THE SAMPLES TESTED. THE TEST RESULTS ARE NOT A GUARANTEE OF THE QUALITY OF THE PRODUCT FROM WHICH THE SAMPLE WAS TAKEN OR OF ANY OTHER PRODUCT. EDWARDS OR PROCEDES TESTING COMPANY, INC. CONDUCTS QUALITY CONTROL PROGRAMS FOR THE CLIENT TO ENSURE THE TEST REPORT IS AN ACCURATE REFLECTION OF THE QUALITY OF THE CLIENT'S PRODUCT. THE CLIENT'S RESPONSIBILITY IS TO ENSURE THAT THE TEST REPORT IS USED ONLY FOR THE EXCLUSIVE USE OF THE CLIENT TO WHOM THEY ARE ADDRESSED, AND THAT THE NAME OF EDWARDS OR PROCEDES TESTING COMPANY, INC. IS NOT USED IN ANY MANNER IN CONNECTION WITH ANY OTHER PRODUCT WITHOUT PRIOR WRITTEN APPROVAL. SAMPLES NOT DESTROYED IN TESTING ARE RETURNED TO THE CLIENT WITHIN 30 DAYS OF THE TEST DATE.

A Member of the SGS Group (Societe Generale de Surveillance)

CSB CENTRE SCIENTIFIQUE ET TECHNIQUE DU BATIMENT
ETABLISSEMENT PUBLIC A CARACTERE INDUSTRIEL ET COMMERCIAL
LABORATOIRE PUBLIC ADHESIF AU MINISTRE DE L'INTERIEUR (Sous le N° 100-1000000)
SERVICE SECURITE FEU - LABORATOIRE DE REACTION AU FEU
11, AVENUE JEAN JURES - CHAMPS SUR MARNE - B.P. 82 - 77427 MARNE LA VALLEE Cedex 2
Tel. (01) 44 88 82 27 - Telex (3400) 7 - Telecop. (01) 44 88 82 79 - Bureau: 38 86 CSB

PROCÈS-VERBAL DE CLASSEMENT
DE RÉACTION AU FEU D'UN MATÉRIAU
Prévu à l'Article 88 de l'Arrêté du Ministre de l'Intérieur du 30 Juin 1983 et
l'Arrêté du 28 Août 1991

N° 92. 33993
Valable 5 ans

MATÉRIAU présenté par : la Société FORMGLAS
250 Rayette Road
CONCORD (ONTARIO) CANADA

MARQUES COMMERCIALES : QUARRRYCAST et NATURAL G.R.G.

DESCRIPTION sommaire : Plaques planes opaques.

- QUARRRYCAST comprend une couche de gypse pigmenté et de granulats minéral seconde couche en gypse renforcée de fibre.
- NATURAL G.R.G. : Mélange homogène de ciment et de verre.

Densité = 4,6 (selon le demandeur).
Epaisseur : 7 à 8 mm.

RAPPORT D'ESSAIS N° 92. 33993 DU 07 OCTOBRE 1992
NATURE DES ESSAIS : Essai par rayonnement.
Mesure du Pouvoir Calorifique Supplémentaire.

CLASSEMENT : **M0**

DURABILITE de classement (Annexe 22) : Non finiee a priori.
compte tenu des critères résultant des essais décrits dans le rapport d'essai annexé.

Le classement indiqué au préjuge pas de la conformité des matériaux commercialisés aux décrets relatifs au norme qui sera considéré comme un certificat de qualification tel que défini par la loi de 1983. Cette matérialité peut être attestée par les certificats de qualification remises par le ministere notamment par le moyen NF - Réaction au Feu.

Champs/Mome le : 07

conformity with all the related regulations
imposed by this Department.

It shall be installed properly in accordance
with manufacturer's recommendations.

that neither the name of this Department nor the
test shall be used or quoted in any form of advertisement
or publication of the product.

WARRES No. 57898
Page 1 of 4
(Inse 2)

TEST REPORT
WARRES NO. 57898
BS 476: PART 4: 1970
NON COMBUSTIBILITY TEST FOR MATERIALS

SPONSORED BY
FORMGLAS INTERIORS INC.
250 Rayette Road, Concord, Ontario, Canada, L4K 2G6

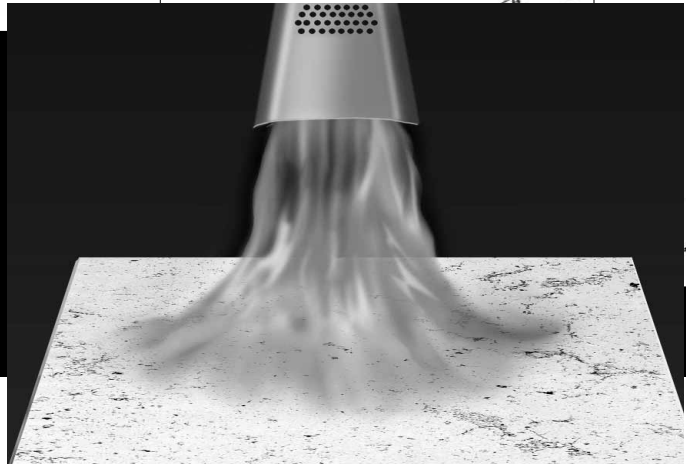

Formglas materials have been tested and approved in most countries. With very low or zero flame / smoke ratings, we exceed the most stringent codes.



Formglas

Formglas Inc.

20 Toro Road, North York, ON
CANADA M3J 2A7
Tel: (416) 635-8030
Fax: (416) 635-6588
Web Site: <http://www.formglas.com>

Formglas (SEA) Sdn Bhd

Lot 590, Persiaran Raja Lumu
Pandamaran Ind. Area,
42000 Port Klang
Selangor Darul Ehsan, Malaysia
Tel: (603) 368-1299
Fax: (603) 367-7795

Formglas Japan Inc.

1-10 - 4 Shinjuku Shinjuku-Ku,
Tokyo 160, JAPAN
Tel: (03) 3225-8397
Fax: (03) 3225-9153

\$ 8.00 (US) \$10.00 (CAN)