

1 COLUMN ELEVATION
SCALE: 1"=1'-0"
REF:

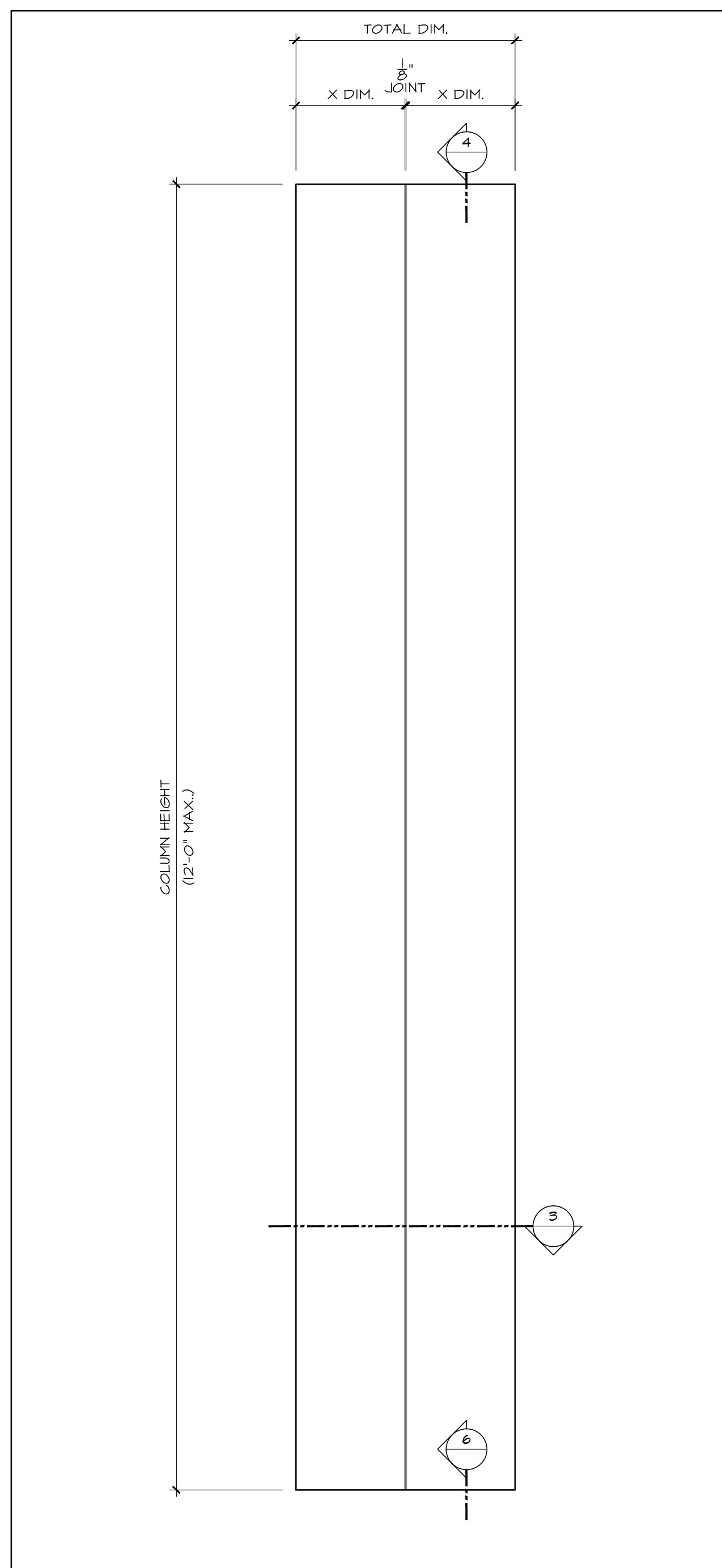

2 COLUMN ELEVATION
SCALE: 1"=1'-0"
REF:

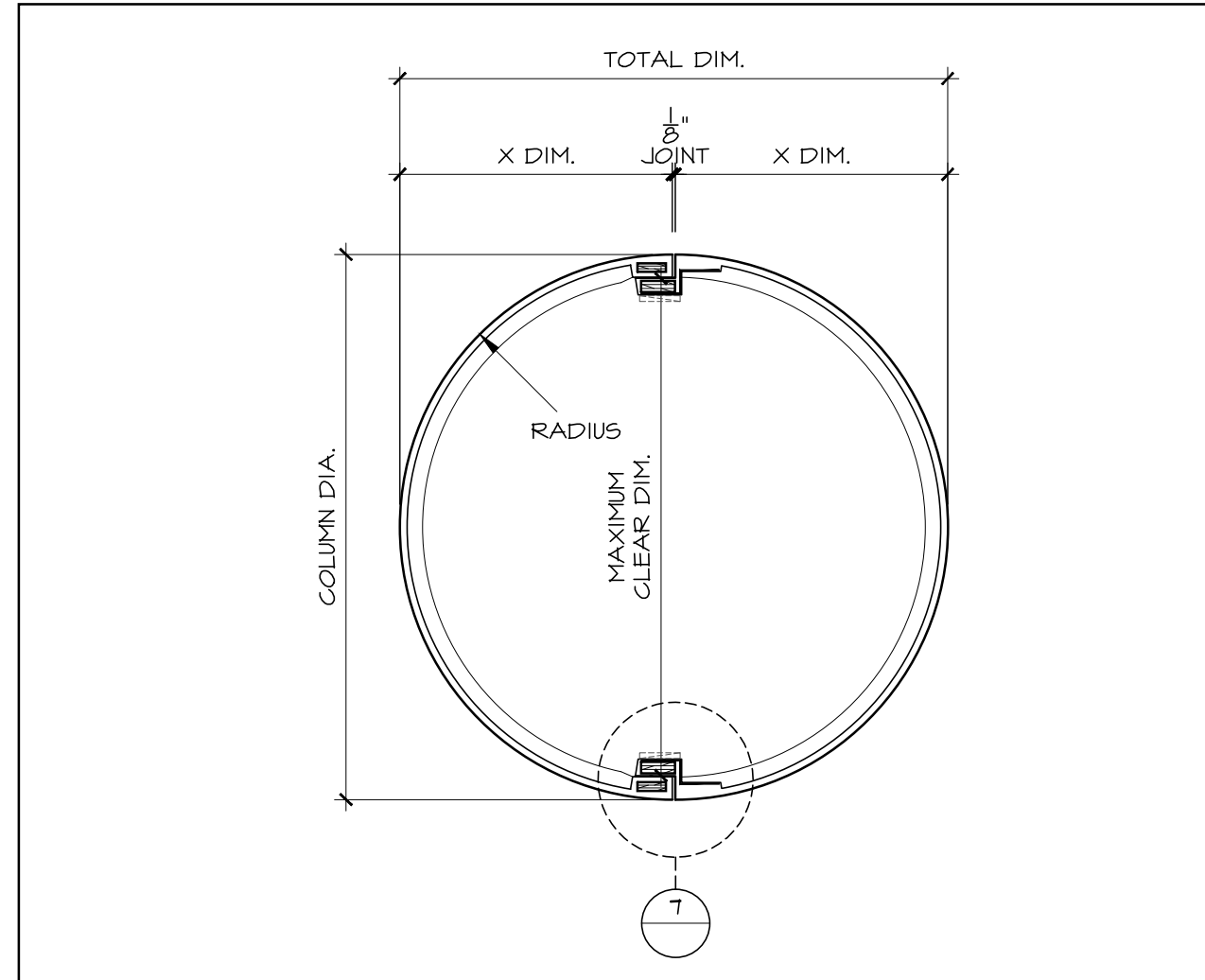

3 COLUMN PLAN SECTION
SCALE: 1/2"=1'-0"
REF:

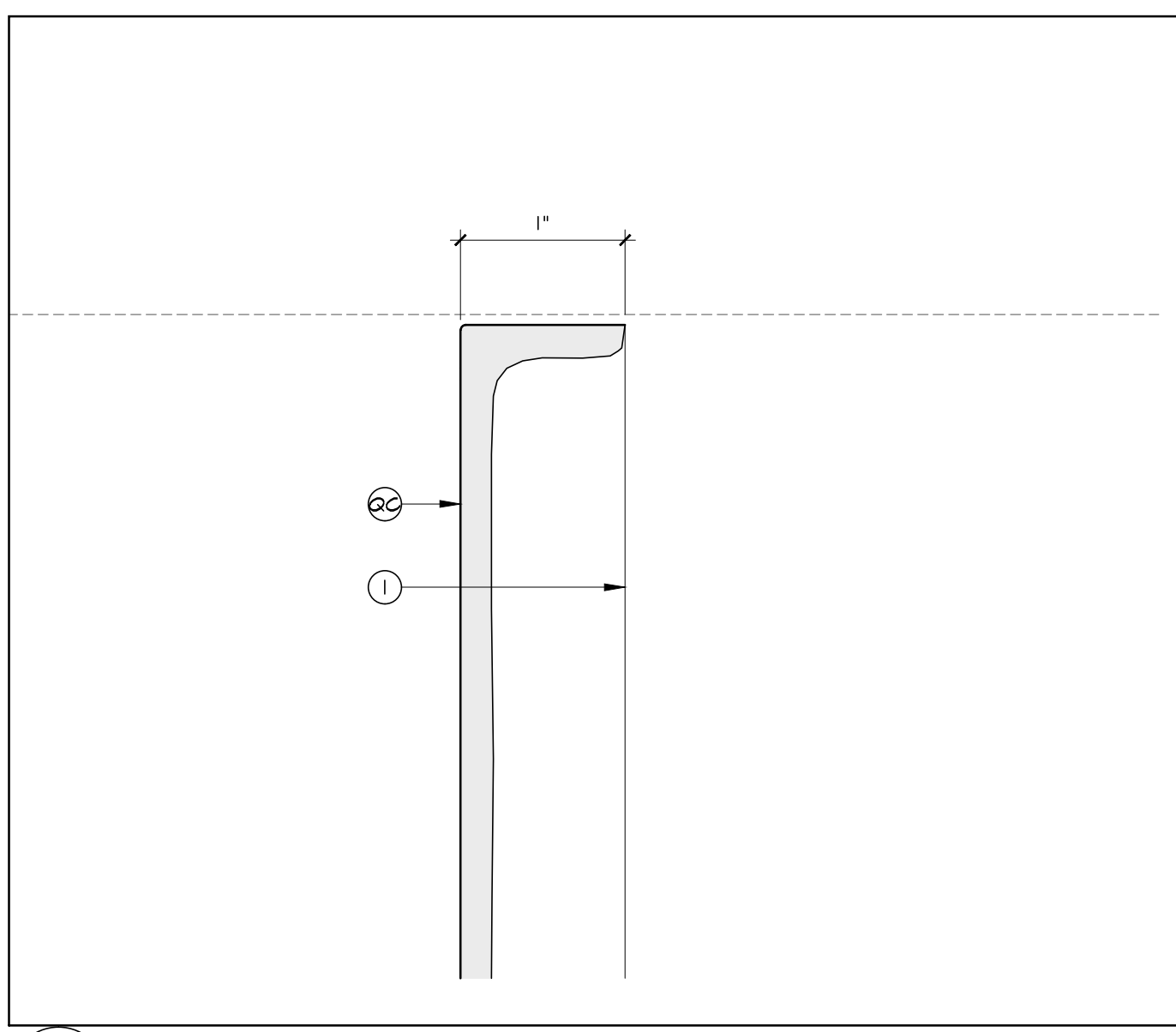

4 DETAIL AT COLUMN TOP
SCALE: FULL
REF:

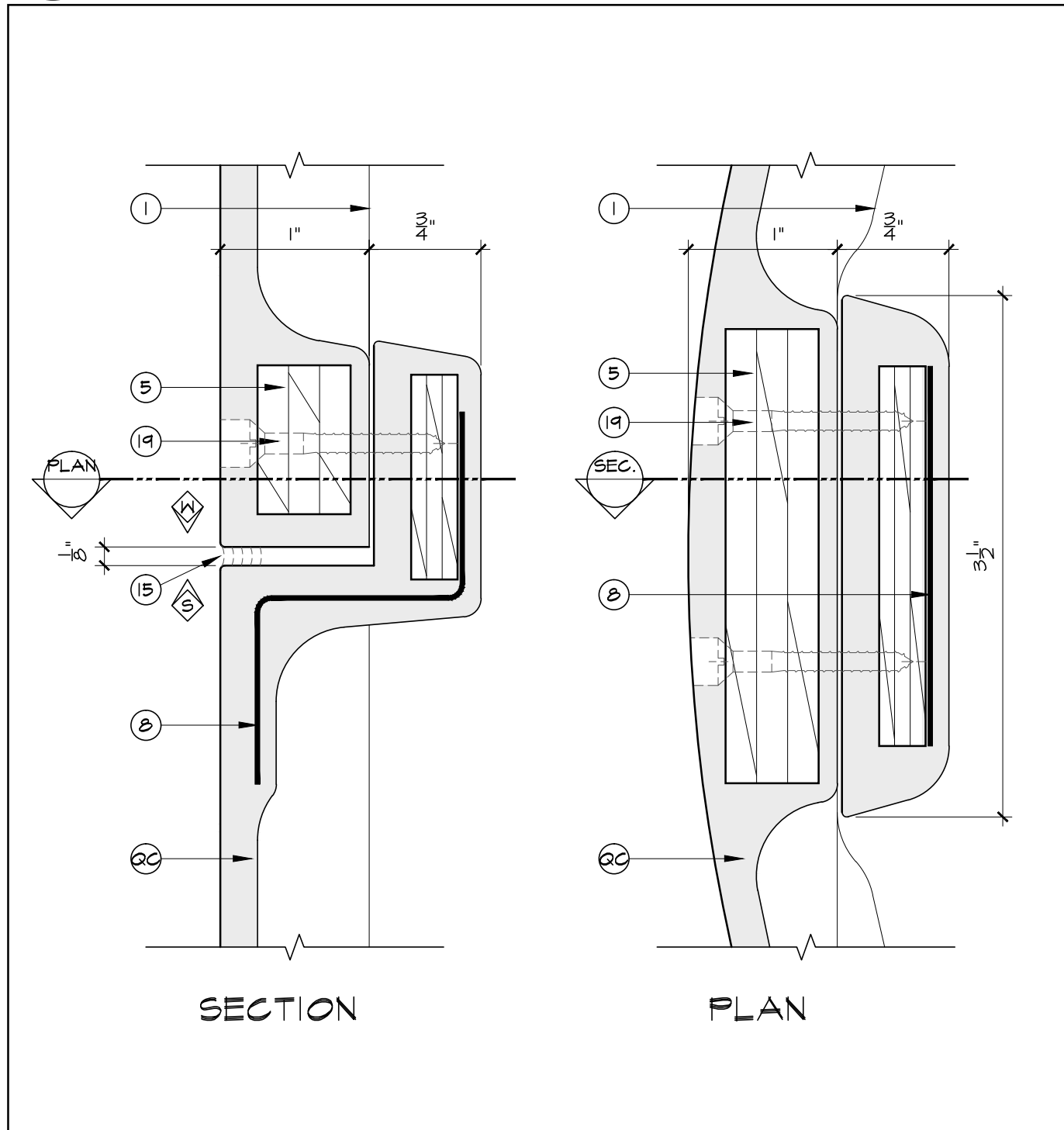

5 HORIZONTAL STACK JOINT
SCALE: FULL
REF:

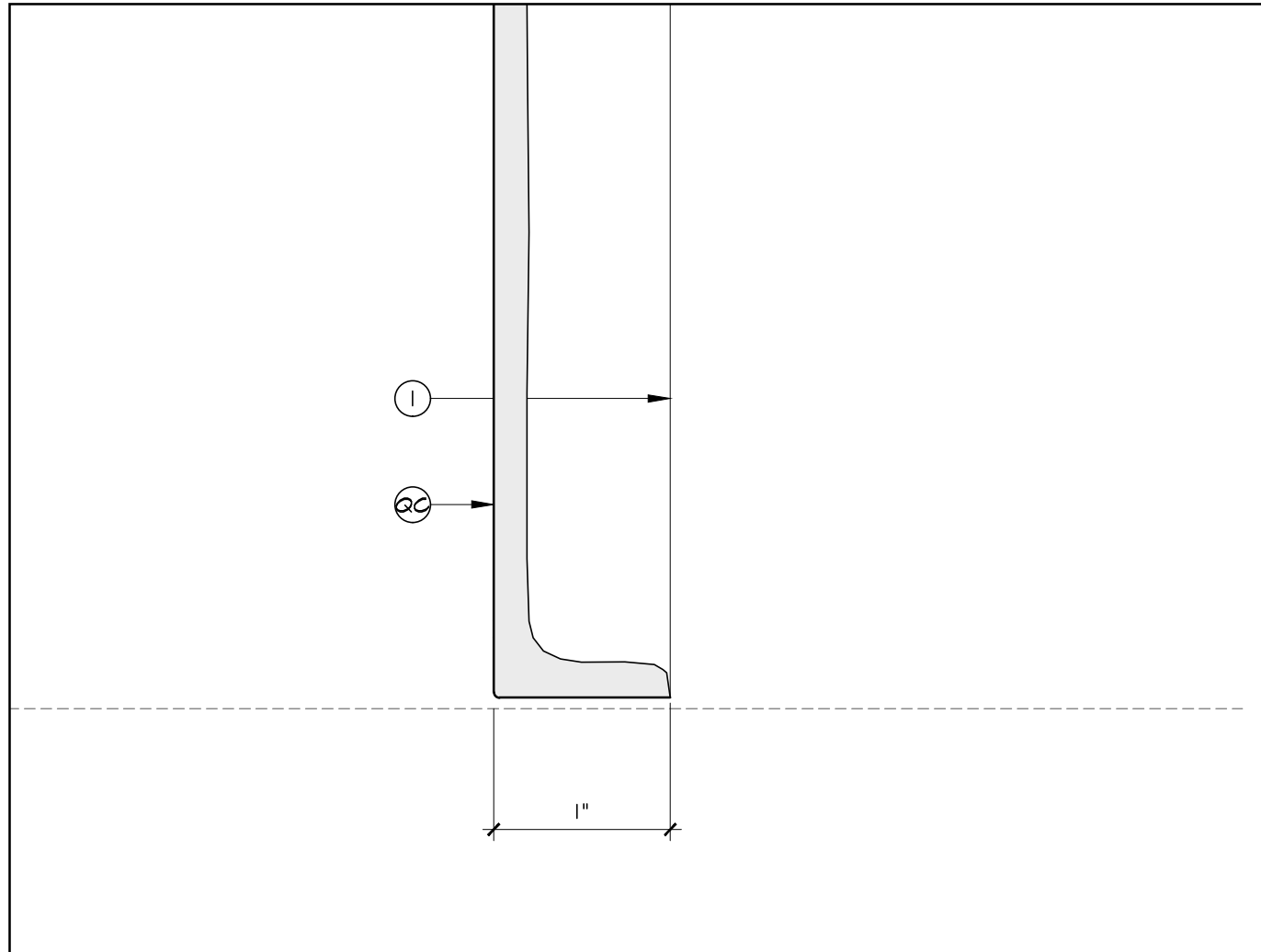

6 DETAIL AT COLUMN BOTTOM
SCALE: FULL
REF:

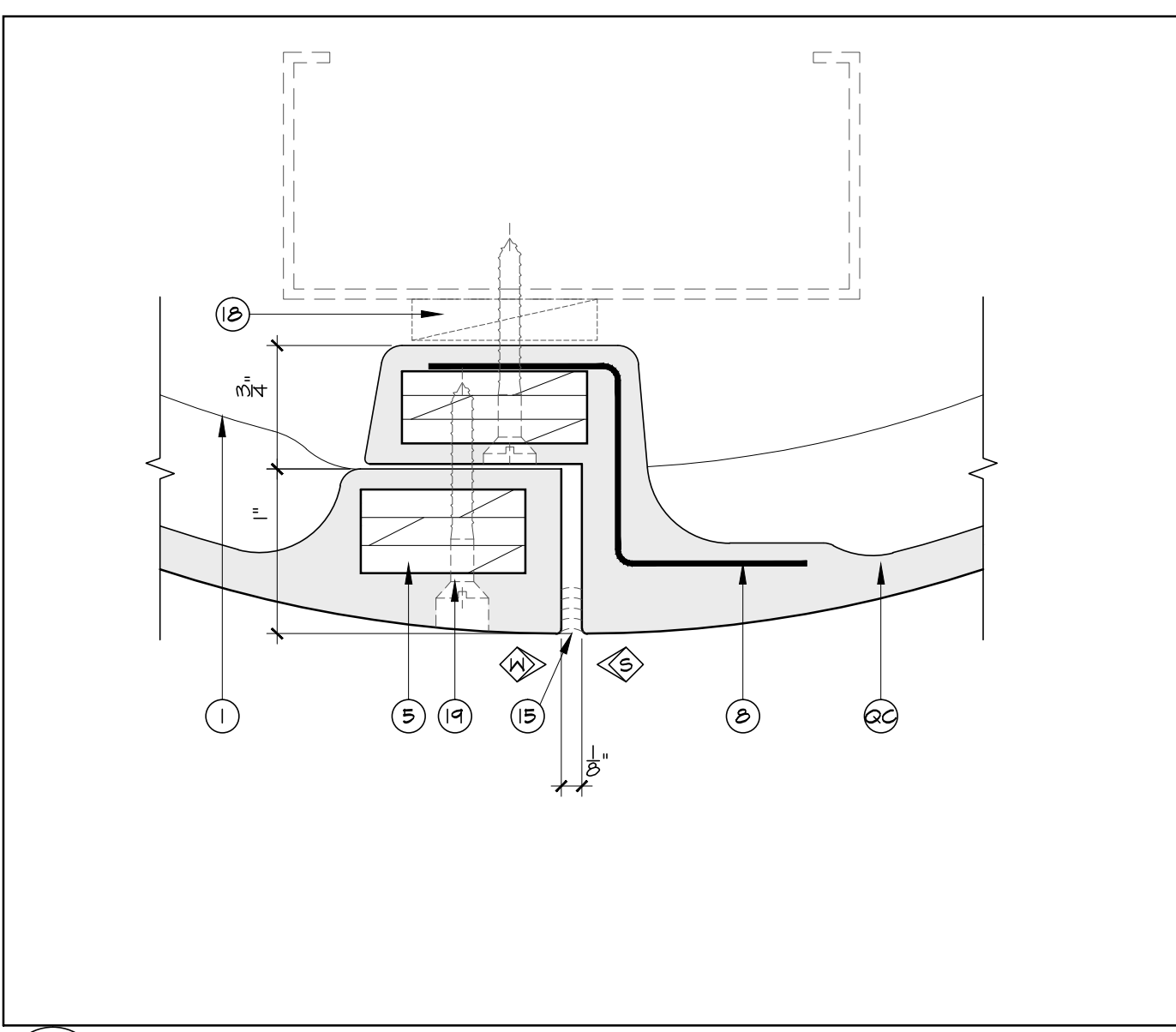

7 OVERLAP JOINT DETAIL FOR COL. GREATER THAN 16" DIA.
SCALE: FULL
REF:

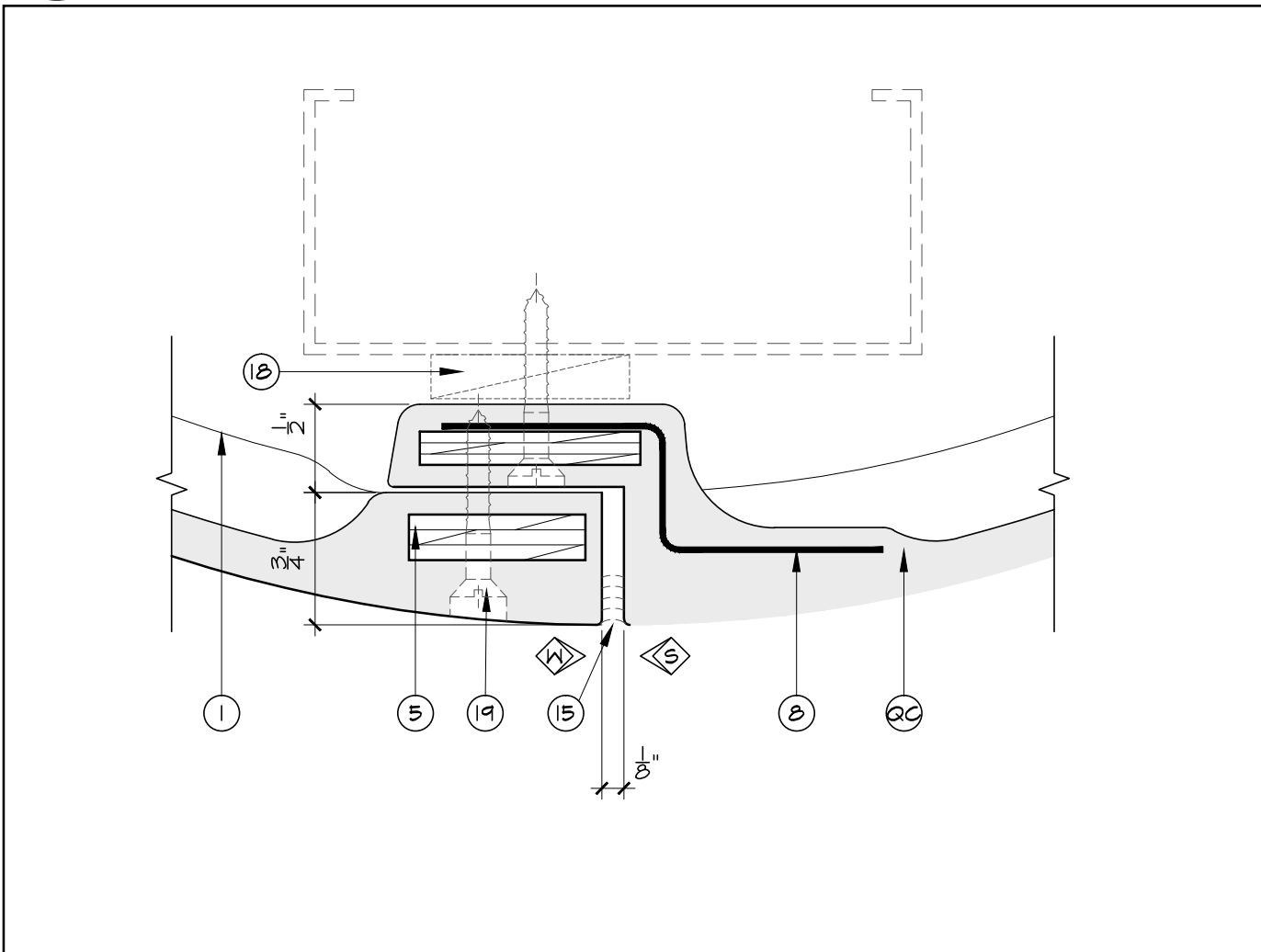

8 OVERLAP JOINT DETAIL FOR COL. LESS THAN 16" DIA.
SCALE: FULL
REF:

STANDARD LEGEND
QUARRRYCAST* (QC)

(QC) QUARRRYCAST* [MOLDED STONE - FACTORY FINISHED]	
(1) FLANGES	(16) DRYWALL OR PLYWOOD BACKING
(2) N/A	(17) FRAMING, BLOCKING, ETC.
(3) JOINT [V]	(18) SHIMS
(4)	(19) SCREWS [FILLED AS REQ'D]
(5) DRAFT PLYWOOD REIN. [CONT.'S]	(20) CAULKED JOINT
(6) PLYWOOD BLOCK INSERT	(21) ADHESIVE
(7) N/A	(22)
(8) STEEL "L" OR "Z" [NOT CONT.'S]	(23)
(9) BUILT-IN "U" REIN. [CONT.'S]	(24)
(10) BUILT-IN ROD REIN.	
(11) BUILT-IN LOOP [HANGER]	
(12) BUILT-IN WOOD GUSSET	
(13) BEVEL EDGES / CORNERS	
(14) FALSE JOINT	
(15) GROUT	

BY OTHERS

(W) WOOD FLANGES
(S) STEEL FLANGES

MISCELLANEOUS

(XX) NUMBER DENOTES RECOMMENDED INSTALLATION SEQUENCE

* ASTERISK DENOTES SITE CUT PART

ALL BUILT-IN STEEL IS GALVANIZED

CERTIFICATION

FORMGLAS IS REGISTERED AS AN ISO 9001-2000 COMPANY

Q.C. NOTES

1. INSTALLATION

- FASTENING, SUSPENSION AND BRACING METHODS INDICATED ARE TO BE CONSIDERED A GUIDE ONLY. THE INSTALLATION CONTRACTOR SHALL ABIDE BY LOCAL CODES, VERIFY JOB CONDITIONS AND ADJUST INSTALLATION PROCEDURES ACCORDINGLY.
- SOME SITE CUTTING AND/ OR GRINDING OF PARTS MAY BE REQUIRED.
- FOR VENEER, USE SPEC. ADHESIVE & HOT GLUE [FOR FAST TACK] WHENEVER TACK NAILING IS NOT POSSIBLE.

2. COUNTERSINK SCREWS OR NAIL HOLES

USE Q.C. MATCHING GROUT SPARINGLY. SMEARING THE GROUT ONTO THE Q.C. SURFACE BEYOND WILL SPOIL THE APPEARANCE.

2A. JOINTS

- NEVER TRY TO MAKE JOINTS DISAPPEAR.
- PANELS - LEAVE JOINTS DRY OR CAULK.
- COLUMNS - CAULK OR USE Q.C. GROUT [SEE NOTE #2 ABOVE].
- MOULDINGS, ETC. - CAULK JOINTS.

NEVER USE DRYWALL TAPING TECHNIQUES

3. COLOUR

TEXTURE AND COLOUR SHADING VARIATIONS WILL OCCUR BETWEEN PARTS. DO NOT TRY TO MATCH SHADINGS IN SPECIFIC AREAS. MIX VARYING PARTS AT RANDOM.

4. DRAFT ANGLES AND RADIUS

DRAFT ANGLES ARE REQUIRED FOR MOLD RELEASE. UNLESS SPECIFICALLY NOTED, REVEALS, SETBACKS OR RETURNS WILL BE DRAFTED BETWEEN 5° AND 10°. ALL CORNERS WILL HAVE A SLIGHT RADIUS UNLESS SPECIFICALLY NOTED.

5. TOLERANCES

SHELL THICKNESS	$\frac{1}{16}$ " (1.6MM) TO $+\frac{3}{16}$ " (4.8MM)
DIMENSIONAL LENGTH OR WIDTH	$\pm\frac{1}{16}$ " (1.6MM)
WARPAGE /BOWING OUT OF PLANE	$\frac{3}{32}$ "/FT (0.07/CM)

FIELD SHIMMING MAY BE REQUIRED

6. ITEMS EXCLUDED

UNLESS SPECIFICALLY NOTED, HARDWARE, CLIPS, FASTENERS, ADHESIVE, CAULKING, ETC. ARE TO BE SUPPLIED BY OTHERS.

7. SEE FORMGLAS* SPECIFICATIONS

FOR ADDITIONAL INFORMATION

8. MOLDS

ALL "CUSTOM MOLDS" WILL BE DESTROYED ONE MONTH AFTER DELIVERY OF MATERIALS. CONTRACTOR/ OWNER MAY NEGOTIATE TO RETAIN MOLDS.

8. NOTE

DRAWING APPROVAL CONSTITUTES REVIEW OF CONTENT, STANDARD LEGEND, GENERAL NOTES, COLORS/FINISHES/TEXTURE/PATTERN AND DIMENSIONAL VERIFICATION.

FORMGLAS PRODUCTS LTD. WILL PROCEED WITH MANUFACTURING UPON RECEIPT OF WRITTEN APPROVAL OF SHOP DRAWINGS AND CUSTOM COLOUR/TEXTURE SAMPLES.

QC COLOUR SELECTION: TO BE VERIFIED

ISSUED FOR APPROVAL

REVISIONS _____ DATE _____

Formglas
Products Ltd.

2 CHAMPAGNE DRIVE, TORONTO, ONT. M3J-2C5 CANADA
TEL: (416) 635-8030 FAX: (416) 635-6588
338 FOURTEEN ST, SUITE 150 AMBRIDGE, PA 15003 USA
TEL: (724) 266-1220 FAX: (724) 266-7174
AVE. RUBILINA 88, PARQUE INDUSTRIAL PALAZO, MEXICALI, B.C.
TEL: (686) 582-7609 FAX: (686) 582-7615
E-MAIL: ENG@FORMGLAS.COM

QC COLUMN ELEVATIONS/PLAN/DETAILS

DATE: _____ SCALE: AS SHOWN
DRAWN: _____ CHECKED: _____
DRWG: _____

DATE: 03_OCT_2011 - 5:03 PM
FILE NAME: C:\USERS\BIBIANA\APPDATA\LOCAL\TEMP\APPUBUILD\894A\QC COLUMN DETAILS.DWG